

EN

**SCHNEESTERN**

action sports engineered



**Prices**  
on request

**BIKE**





Action sports is our DNA. But what does this mean, what are action sports? For us, it's the kind of sport that makes your pulse beat faster and always provides a little thrill. Action sports are unique, and this means that everyone can experience them in their own way. Be it young or old, beginner or professional, on a bike or skateboard.

Opposites that are not really opposites and yet determine our daily work. We have made it our task to make action sports a real experience for everyone, bringing it from the professionals to the broad masses. We have been using our know-how since 1999, we go to the office, to the workshop, up the mountain or to the construction site every day, in order to further sustainably establish action sport and its culture in society. No matter whether this is through a tourist concept or within the framework of municipal physical activity promotion.

In order to achieve this goal in the field of biking, we trust our years of experience in building action sport parks. Our passion and the gained know-how from "20 years of Schneestern" are the perfect combination for transforming society through the positive effects of bike and action sports. The results are well-thought out and sustainable trails and facilities—from pump track to downhill trail. We have consolidated a comprehensive portfolio of products in our BIKE division at Schneestern.

Our product range adds value and benefits to our customers, helping them master their challenges with suitable solutions. We want to help cities, municipalities, planners, mountain cableways, tourism destinations and sporting clubs to make full use of the potential of purpose-built bike trails and facilities. Through this we generate a positive impact for society, today and for the future. Are you possibly looking at building a pump track or a bike park? We are the perfect partner and aspire to the highest levels of quality and technology according to our company motto: "action sports engineered"



## Social Return

8

## Bike Parks

Services	16
Facility Features	18
Structural Engineering	19

## Routes / Trails

Trail park	28
Flow trail	34
E-Bike trail	38
Freeride trail	42
Jump trail	44
Single trail	48
Downhill trail	50
North shore elements	52

## Facilities

Pump track	60
Balance bike track	64
Jump track	66
Practice course	82
Indoor Park	86
BMX Racetrack	88
Dirt Park	90

## Bike Equipment

Safety	94
Customer service	96
Delivery	97
Practice elements	100
Artificial obstacles	112
Safety concepts / Add-ons	118
Modular pump track	130
Contact	147

# Social return

Riding a bike is fun. Anyone who likes to ride a bike or has seen children smiling from ear to ear after their first few laps on a pump track knows this. Biking makes us happy, but how far do the positive effects go and how can they be recognized? Our answer to this is social return. By this, we mean the social added value that is generated by the construction of bike trails and facilities.



## The problem

Whether young or old, we move too little, live too unhealthily and spend too much time in front of technical devices. At a time when stress has become a widespread condition as well as people becoming increasingly dissatisfied and isolated from each other, the urge for finding solutions is crucial. Smartphones and computers have become more important to individuals than personal social interaction. "Togetherness" exists more in the virtual world than in reality. It sounds almost paradoxical: In the "mobile age", it is us ourselves who move less and less. Every fifth child and even every second adult in Germany is overweight. Consequently, only 14 percent of Germans are considered completely healthy. It is a phenomenon that can be observed in most Western countries: People are overweight, too sluggish, under stress or always on their phones. What do these conditions say about our society and—more importantly—what do they mean for children and teenagers?

## The answer

It is precisely these problems which social re- turn addresses as an overall concept. There are four central areas in which the positive effects of riding can be seen: Education, social integration, competitive sports and health.

All of these four elements generate a con- sistently positive effect and address many of the social problems of our time.

### Education

Simply speaking: If you spend more time doing sports, there is less time for nega- tive activities such as watching televi- sion, smoking or drinking alcohol. Sports provide a healthy balance to studying. In addition, sports support the development of positive social functions and non-cog- nitive skills such as motivation and self- discipline. Thus, contributes passively to the learning and educational process of children and young adults.

**Fact: After school sporting activities increase the probability of obtaining a bachelor's degree at a later date.**

### Social Integration

Sports create a sense of community, social commitment and solidarity. Sports are particularly important in childhood and adolescence. They teach values such as fairness, respect, willingness to perform, promotes self-development and supports the learning of basic democratic values.

**“Sport in particular can help to break down existing prejudices and fear of strangers through the personal and active encounters of young people.”**

Otto Schily,  
former German Federal Minister of the Interior

SOZIALE  
RENDITE

### Competitive sports

Competitive sports, which can only be promoted through appropriate sporting facilities, have an unprecedented role model function for economically relevant values such as motivation, creative personal achievement, initiative and performance. Competitive athletes are idols and convey collective feelings such as satisfaction, joy or pride.

**Fact: Following friends & family, competitive athletes are among the greatest role models for Millennials in Austria.**

### Health

Sport keeps you healthy! A lap on the bike contributes to our well-being, physically and mentally. Not only do they prevent widespread illnesses such as cardiovascular diseases or obesity, participants are also demonstrably happier.

Mens sana in corpore sano—a healthy mind in a healthy body.

**Fact: Up to 16% of total health costs are due to physical inactivity.**



# The social return in use:

In theory, social returns sound exciting and promising, but how does it benefit in practice? The asphalt pump track in its function as a multi-sport facility is a perfect example of this. (More about the product pump track from page 64). Using seven pump track projects that have already been implemented, we have analyzed the health component of the social return and determined average values for comparison. To do this, we collect data from on-site counting systems and our observations.

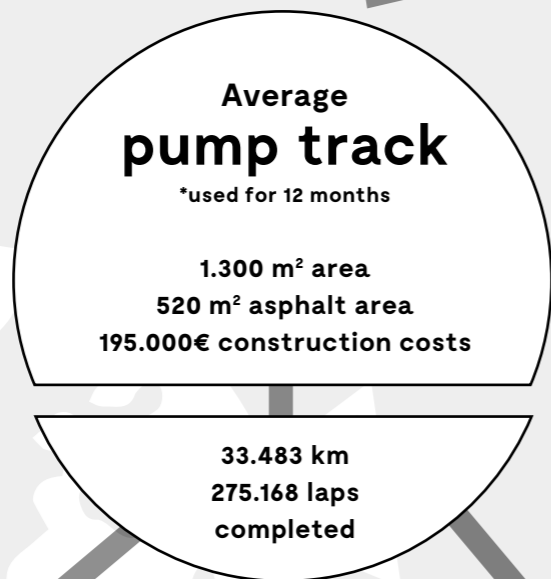

69 days of usage time  
= 1.656 hours without  
a mobile phone

1,34 million. calories (kcal) bur-  
ned = 1.821 burgers + soft drinks

0,84 times around  
the equator

## Health benefits

within 12 months for an average pump track \*

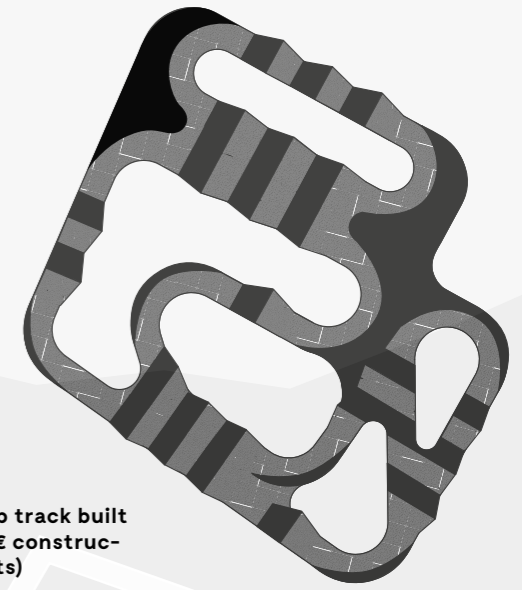

per pump track built  
(150.000€ construc-  
tion costs)



one minute  
without  
mobile phone  
costs 1,96€



a saved burger  
meal costing  
107€



a travelled  
kilometer  
costs 5,82€ or  
a lap 1,41€

per m<sup>2</sup> asphalt  
pump track



3.2 hours  
without  
mobile phone



3.5 burger +  
soft drinks or  
2,576 calories  
consumed (kcal)



64 kilometers  
covered or  
530 laps completed

The math is simple:

Targeted investments in the appropriate multi-sport facilities at the correct size, result in maximum social returns. The mental and physical health of the population is a social added value of our facilities. This perspective sheds a completely new light on the construction of pump tracks. Investments in pump tracks can be aimed at their social added value, an aspect that is particularly important for the sporting and social needs of children, teenagers and adults.

\* Assumptions:

- Energy consumption for riding a pump track = 800kcal/h at 20km/h (40kcal/km)
- 30% of participants are scooter riders. Not technically measurable but approximated by random sampling
- Burger + Softdrink = 515 kcal + 220 kcal



**BIKE**  
PARKS



# Service Portfolio

## Planning & Construction

➔ For builders

### I. Acting as building contractor (bidder)

#### 1. Construction

- Constructional realization according to plan
- Project management and documentation
- Quality assurance and construction supervision
- Subcontractor management
- Equipment supplier
- Initial safety inspection (e.g. TÜV)
- Care and maintenance work
- Staff training

#### 2. Renovation

- Renovation of existing facilities

#### 3. Support and marketing

- Editorial articles in the trade press
- Photo and video production
- Opening event
- Highlight Events
- Testimonial arrangements
- Sponsorship arrangement



### II. Acting as sole contractor (§ 7c VOB/A 2019)

#### 1. Planning and construction by a single company

Advantages:

- Lower overall project costs (planning + construction)
- Fixed-price contract guarantees cost security in planning and construction
- Faster project implementation
- Less project complexity (interfaces, contact persons, allocation, etc.)
- Optimal sports-functional and needs-based implementation

#### 2. Specialist work in the planning phase

- Preparation and coordination of the performance program
- Preparation and coordination of sole contractor agreement
- Basic assessment
- Preliminary planning and estimation of costs
- Information event and project presentation
- Participation process (stakeholder process)
- Draft planning and calculation of costs
- Implementation planning
- Submission documents (e.g. building application)
- Approval and funding procedures
- Preparation of tender documents for subcontractors
- 3D visualization
- Safety and signage concept

#### 3. Technical work in the execution of construction work

- Constructional realization according to plan
- Project management and documentation
- Quality assurance and construction supervision
- Subcontractor management
- Equipment supplier
- Initial safety inspection (e.g. TÜV)
- Care and maintenance work
- Staff training

#### 4. Support and marketing

- Editorial articles in the trade press
- Photo and video production
- Opening event
- Highlight Events
- Testimonial arrangements
- Sponsorship arrangement

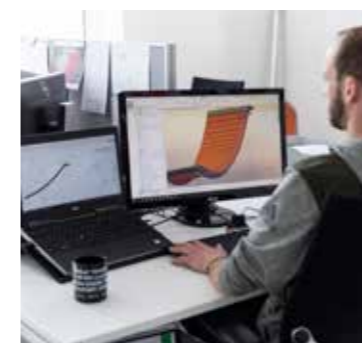

➔ For planners

### I. Acting as a subcontractor

#### 1. Initial consultation and exchange of know-how

#### 2. Analysis and fixation of requirements

#### 3. Specialized contributory work as a subcontractor (LP1-6):

- Basic assessment
- Preliminary planning and estimation of costs
- Participation process (stakeholder process)
- Draft planning and calculation of costs
- Implementation planning
- Submission of documents (e.g. building application)
- Approval and funding procedures
- Preparation of tender documents
- 3D visualization
- Safety and signage concept

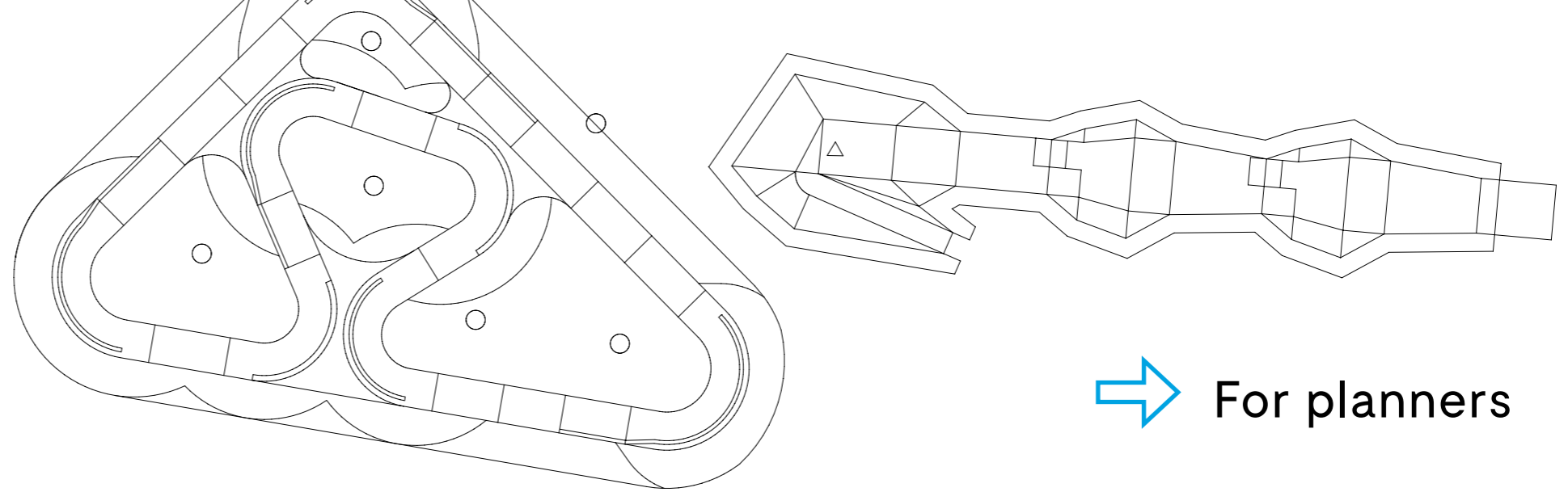

# Track and facility characteristics

In order to simplify the overview of such individual products, we have summarized the most important characteristics and information on the individual track and facility components. We have presented them in clear and understandable level chart.

Basically, we divide our tracks and facilities into four levels of difficulty. In doing so, we refer to the widely known and standardized color coding for ski slopes. The sections are intended to help maintain an overview whilst dealing with diverse products. The individual levels of difficulty are directly combined with one another. It is our aim to appeal to as wide an audience as possible, which is why we take care to consider the needs of beginners, advanced and professionals alike when planning.



CHARACTERISTICS	VERY EASY	EASY	MODERATE	DIFFICULT
Track width	wide	usually wide	medium to narrow	narrow
Ground	leveled and firm	stable and firm	loose in certain areas	very differing
Line management	straigh lines, very simple curves	wide simple curves	individual, varying curves	differing curves narrow curve combinations
Gradient (average)	<5%	< 10%	< 20%	>20%
Natural obstacles	none	none to a few small ones	several medium-sized ones	many, including large ones
Artificial obstacles	none	rollable	rollable	partially not rollable

# Structural engineering

Primarily, we see ourselves as a service provider for the planning and construction of bike trails and facilities. Therefore, we are basically a traditional construction company in the modern business field of action sports. In this context, many facets of structural engineering play an important role. Below is a clear overview of what exactly this means for the implementation of bike trails and facilities.

## Construction measures

Here we distinguish four basic types of construction measures, whose composition, in turn, defines the overall extent of the building process.



### Construction works

Depending on the trail or the layout of the facility, operations can be carried out manually or with the use of machines. In general, sensitive areas and protective zones are worked on manually, whereas machines are used for uncomplicated and major operations.

Our machine partner:



### Tampering with nature and landscape

Different demands on the facility and the layouts of trails require an adjustment of the terrain and thus an impact on nature. For example, in the case of beginner-friendly trails, steep terrain may have to be leveled or a path created for forest sections.

### Water management

When building bike trails and facilities, it is extremely important to know how to deal with heavy rainfall. Drainage systems are essential, especially for jumps and banked curves, but also for larger sealed areas.

After all, efficient drainage not only means longer periods of operation, but also less maintenance work.

### Artificial obstacles / equipment

Often, natural obstacles do not meet the requirements of the respective track or type of facility and must therefore be extended by artificial sections. The possibilities range from additional stone fields to complex constructions made of steel and wood. Any kind of artificial elements are possible.



# Sustainable construction

As a company with many years of experience and a historical relationship to action and bike sports, we spend a lot of time outdoors, both professionally and privately. Therefore, we see it as our responsibility as a construction company to keep a minimal “footprint” in nature. Sustainable building is our top priority in addition to quality and customer satisfaction.

For us, sustainable construction consists of three fundamental factors:

## Building the “right thing”

For us, sustainability means first and foremost building the right track/facility for the right target group. Multifunctionality should always be the main focus in order to reach as many sporting groups as possible. Relevant sporting facilities which are tailored to the sporting behavior of current and future generations. This is the only way to guarantee that facilities are being used sustainably and for as long as possible, further reducing often unnecessary construction work which occur due to changes in sporting behavior and therefore minimizing the impact on nature



## Impact on nature

Of course we aware that we have an undeniable impact on nature. Therefore, when it comes to the impact on the natural environment, our basic principle is: “As much as necessary, as little as possible”. We limit the changes in organic terrain to a minimum and consciously focus on renaturation.

Even if many construction measures seem irreversible at first glance, a well thought-out approach can restore parts of the original “nature”.

## Longevity

Building “the right thing” is only effective if you also make sure that it lasts for as long as possible. That’s why under the aspect of sustainable construction, the focus is also on the longevity of our track/facility. All central points of our construction measures as well as the choice of building materials are aimed at keeping maintenance costs as low as possible while showing maximum durability against wear and tear.

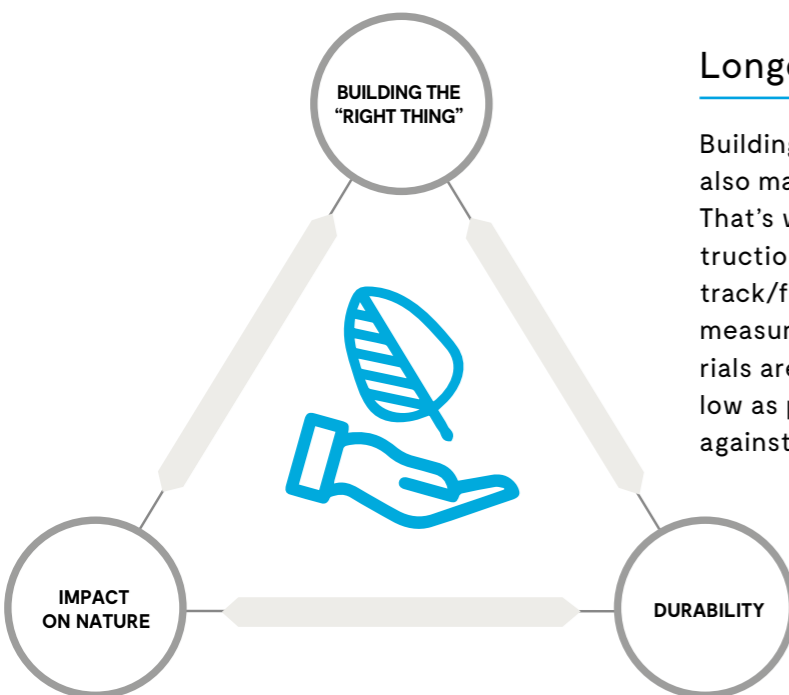

## Maintenance / running costs

In addition to the one-off construction costs for a bike track or facility, the running costs must be considered. If facilities are frequently used or exposed to strong weather conditions, regular maintenance and repair measures, e.g. refixing, are required depending on the track surface. The work involved here can range from an almost maintenance-free asphalt pump track, to simple manual work on a structurally fixed flow trail, to the annual mechanical reworking of unpaved jumps in a dirt bike facility.



# Track surface

The track surface is a decisive criterion in the selection or construction of a facility or track, as it not only influences the degree of difficulty but also provides information about the expected maintenance and repair work as well as accessibility in wet conditions. We distinguish between three categories:

## Unsurfaced/unpaved

- Pro:** Affordable, quick to construct, natural experience
- Contra:** More intensive maintenance work, increased risk of accidents, increasingly demanding track quality, not suitable for all soils



## Fixed track surface:

- Pro:** Easy to ride on, low rolling resistance, more resistant to wear and weather conditions
- Contra:** Greater planning requirements, visible impact on nature, extended timeframe for implementation, increased costs



## Asphalted

- Pro:** Extends the range of uses, virtually maintenance-free, vandal-proof
- Contra:** More complex construction measures and higher initial costs



More information on asphalt as a track surface can also be found on page 78.





“From the city to the heart of nature, high health and tourist value added and an extremely large target group—trails that offer more than just getting you from A to B.”

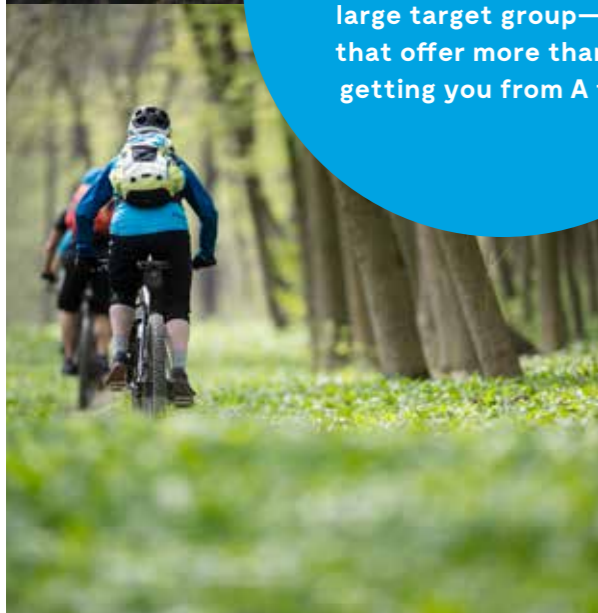

# ROUTES / TRAILS

# Target groups— Routes / Trails

For example, 15 million people, a good quarter of Germans between the ages of 14 and 69, use a mountain bike in their spare time. Of these, 3.8 million use their bikes regularly. Therefore, it is not surprising that mountain bikes are also very important when travelling. 16 percent of the population are (very) interested in mountain biking whilst on holiday.



Source: GfK Austria (2015)

Demand for mountain biking on holidays and in leisure time  
Graphic: Mountainbike Tourismusforum Deutschland 2019

In general, mountain bikers can be divided into six disciplines or segments. This has developed mainly from the different requirements of mountain bikes (frame geometry, suspension, etc.) and the recreational preferences of their users. A reduction to four instead of six segments makes sense from a touristic point of view for various reasons: This allows segments and target groups to be considered with a relevant volume, instead of making too small a distinction. Some of the segments have very similar infrastructural requirements. Hence, a differentiation is not useful for the product development of a destination. Most Mountain bikers associate themselves with

several segments. Through the consolidation, target groups can be more clearly distinguished from each other. The target group zero should be considered separately, but nevertheless in a direct context. A mountain biker unaware of being one yet presents an incredible potential. The goal here is to make it as easy as possible for beginners and families to get started. The motto must be to "exhilarate" instead of "deter". It is about fun experiences in nature lying within the comfort zone of the guests.

potential guest	current mountain bike segments	
<b>target group 'zero'</b> Bicycles become bikes – trendy, with higher spring deflection, better brakes and often also power units. Just as the vehicle changes, so do consumers. They are characterised by a high activity and motivation to exercise, as well as a strong desire to spend time in nature. The mountain bike scene and their lifestyle attract them.	<b>Tour</b> For you, mountain biking means <b>relaxation</b> .	<b>MaXC</b> <small>marathon/cross country</small> For you, mountain biking means <b>endurance sports</b> .
	<b>AMEN</b> <small>all mountain/enduro</small> For you, mountain biking means <b>adventure and performance</b> .	<b>FRoDHo</b> <small>freeride/downhill</small> For you, mountain biking means <b>rapid descents and action sports</b> .

images : World of MTB, MTB Vier-Hübel-Tour, Dennis Stratmann, Thomas Dietze/ExtremePics, Andhika Soreng

Segments of the established mountain bike market and the market potential  
Source: Mountainbike Tourismusforum Deutschland 2019

The bike sport is versatile and in order to simplify the overview of such individual products, we have classified the most important types of trails / facilities according to the two decisive characteristics

of difficulty and breadth of the target group. This allows you to evaluate the potential of the respective facility at a glance.

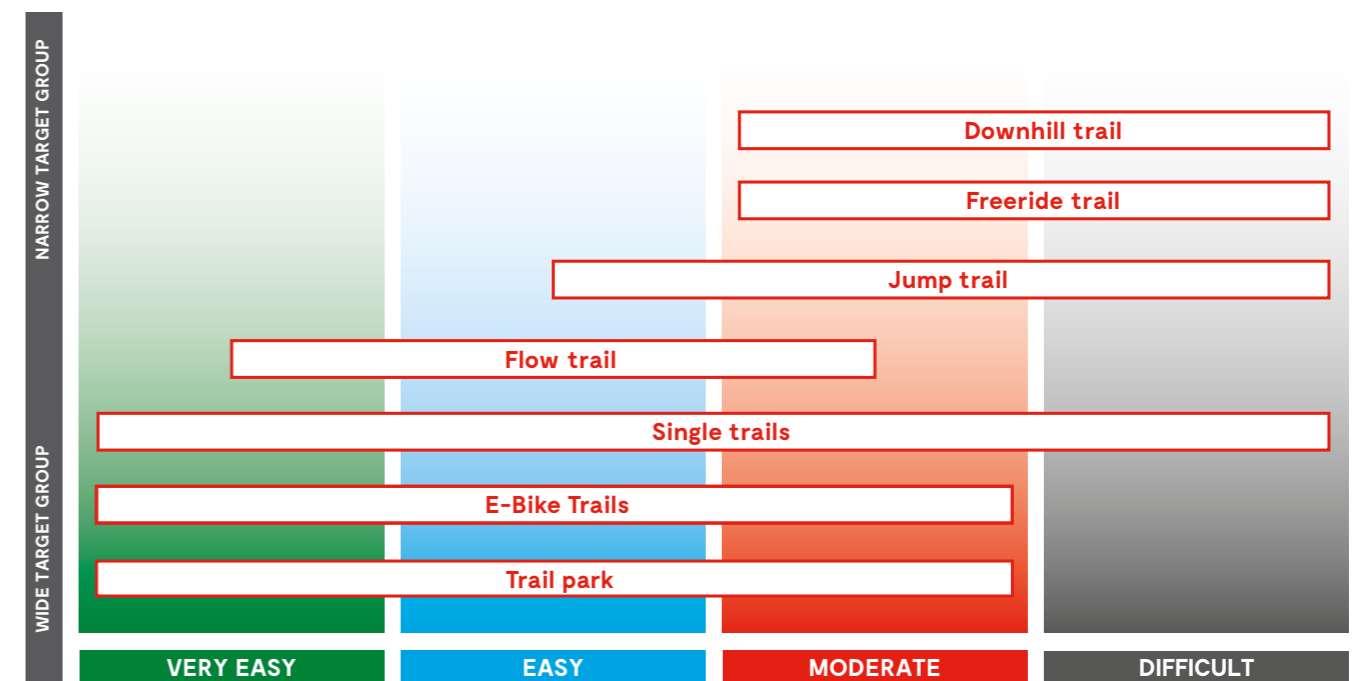

# Trail park

Trail park—a new trend in the world of mountain biking, which actually is not that new. The world's first trail park opened its doors in Wales back in 1991, laying the foundation for an exciting concept for mountain biking. The principle behind it is as simple as it is genius. Starting from a central junction (trailhead), a network of single trails, with tracks (only accessible in one direction) of all levels of difficulty, spreads out. On the individual trails, uphill and downhill passages alternate with one another, focusing very clearly on the descent. However, in contrast to the classic model of the bike park, the trail park does not offer any aids to

ascent. An exception to this is the fact that modern trail parks are becoming increasingly popular with e-bikers due to their uphill character. Despite its sporty character, the park is designed for as broad an audience as possible thanks to its balanced degree of difficulty. The magic word “flow” also plays an important role in the trail park. Meaning the individual trails are never too steep and clearly “flowy” in nature. The increasing level of difficulty does not result from the incline, but from additional obstacles and an increasing length of the trail.

## These are the benefits of a trail park

- Trailhead as central point for the infrastructure everything relating to the mountain bike: bike shop, rental, workshop, catering, practice course, etc.
- Several tours offered on different trails on the same day
- Attractive for stays of up to several days given an appropriate offer of trails
- Groups (e.g. families) consisting of all skill levels, can enjoy themselves together in one place.
- Perfect for low mountain regions, as the terrain only has to have a small difference in altitude (less than 100 m).
- Lower maintenance costs, as flat trails are generally more sustainable in maintenance.

## Characteristics

### target group

- Tour; Marathon/Cross-Country
- All Mountain/Enduro
- Freeride/Downhill
- Target group zero

### difficulty level



### construction measures



### current costs



### surface

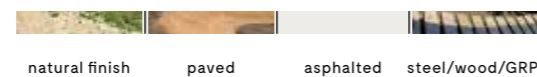

### cost per square meter



# Best practice trail park: Singltrek Pod Smrkem



## More than just another infrastructure!

The Singltrek pod Smrkem in the Czech town of Pod Smrkem is a formally organized network of narrow paths built artificially, near-naturally and over a total length of 80 km for mountain biking. With their narrow width and gravel track, they blend in perfectly with the surrounding forest. In contrast to wide downhill slopes, the other forest users perceive them to be pleasant and (well) integrated.

Above all, the Singltrek pod Smrkem is a complete tourist product and a strong brand. Singltrek stands for accessibility, marketability and high quality combined with maximum safety. The return on investment has been tested and proven in numerous trail parks worldwide.

More information and impressions can be found at: [www.facebook.com/pg/singltrekpodsmrkem](http://www.facebook.com/pg/singltrekpodsmrkem)



**“In the Czech Singltrek pod Smrkem, one attracts 50,000 visitors/year with an added value of 1 million EUR. Applied to German-speaking low mountain ranges in a metropolitan region with the support of a professional destination developer, the potential is enormous.”**

Nico Graaf  
Mountain bike Tourism Forum Germany

## Value

At Singltrek Pod Smrkem, the figures speak clearly for the project and for the concept of the trail park in general

**1. Mio €**  
economic value added / year



**1.7 Mio €**  
health value added / year



**50.000**  
visitors / year

**120.000**  
overnight stays / year



PARKS

Services

Facility Features

Engineering

Routes/Trails

Facilities



# Best practice trail park: Hohe Wand Wiese (Vienna)



## Pure local recreation!

Vienna is a cosmopolitan city and home to millions. It's not necessarily one of the places where you would expect a huge MTB trail network and a modern trail park concept. Yet, the MTB trails in the Vienna Woods and around the MTB center "Hohe Wand Wiese" offer the inhabitants of Vienna a unique local recreational experience. Here, almost 1000 km of designated MTB routes have been operated by the Tourism Association since the mid-1990s. However, this is only one part of the overall concept:

Since 2014, an attractive new development has been initiated and implemented together with all stakeholders involved. So far, this has resulted in the trail park Weidlingbach, several hiking trails specially approved for joint use and the MTB center Hohe Wand Wiese. A consistent expansion of the trails is already firmly planned. Thus, exemplifying that the vision for the Vienna Woods is greater: over the coming years, a trail region will be created consisting of trail parks and the old MTB trail network. This results in the following benefits for the region:

- **Modern local recreation concept for the entire region**
- **Creation of an integrated infrastructure for the popular sport of cycling/MTB**
- **Management of recreational use—conflict minimization between user groups**
- **Added value for the region—bike schools, gastronomy, hotel business**
- **Increase in the number of users of all ages and abilities—promotion of physical activity**
- **Guiding visitors away from "illegal" trails = nature conservation**

More information and impressions can be found at:  
[www.hohewandwiese.com/trailcenter](http://www.hohewandwiese.com/trailcenter)



# Flow trail

The flow trail is exactly tailored to what the modern mountain biker wants: Flow. A route that has its own rhythm, which cyclists can tune into. A flow trail generally consists of a wavy course including many playful elements that create a kind of roller coaster feeling, the so-called "flow". Rollable jumps, waves, S-curves and light corners, which can be mastered without advanced riding

or jumping techniques, make beginners as well as professionals happy. Because a flow trail is what you make of it: a flat trail for the whole family, e.g. as the first entry into the bike park or the ultimate playground for fast and talented riders who want to make full use of their abilities. There is no easier and better way to address all target groups in mountain biking.



## Characteristics

### target group

- Tour; Marathon/Cross-Country
- All Mountain/Enduro
- Freeride/Downhill
- Target group zero

### difficulty level



### construction measures

- low (axe icon)
- medium (pickaxe icon)
- extensive (pickaxe icon)

### current costs



### surface

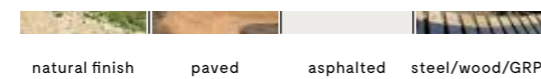

### cost per square meter



## Bike park Oberammergau flow trail

Oberammergau, Germany

The region surrounding the town of Oberammergau is ideal for all kinds of biking. Therefore, a bike park is a must. Local initiators have advocated for the (re-)opening of the bike park "Kobelsattel" located on the mountain Kobelsattel in Bavaria and thereby hired us to design and build the shell of a flowline (approx. 1,200 m) and a jump trail (approx. 400 m). Due to this extension, the bike park Oberammergau offers a wide range of trails that appeals to all athletes, from the first-time bike park user to the professional alike.



## "Bikewelt" Schöneck flow trail

Schöneck, Germany

Since 2009, the flow trail "Bikewelt" in Schöneck has been home to gravity and speed fans with its two downhill trails. Due to the increasing demand for MTB and the desire for a year-round complete facility for a broad target group, the bike park was expanded in autumn. This included building three more trails and the expansion of the existing downhill trails. We were responsible for the planning, development and construction of the existing and new trails. The new concept allowing all trails to be ridden as a combination of flowline, dirt jumps, and downhill trails ensures that the needs of all downhill mountain bikers are met in the most compact space.



## Mini bike park Annaberg flow trail

Annaberg, Austria

The Mini bike park "Annaberg" is a freely accessible mountain bike training area featuring a pump track, skill track, flow line and skill line. In order to practice the feeling of balance, riding, and off-road mountain biking, ranging from the use of balance bikes to professional bikes. The main trail of the Minibike Park, "Flowline" is 700 m long and has a decline of less than 5%. It leads downhill over variety of tracks, including the "Skills Line" which features curve combinations and riding technique elements at the simplest level of difficulty. The facility is used without a lift. An ascending trail leads uphill.



# E-Bike trails

Pedelecs & e-bikes are one of the latest developments in the bicycle industry and have experienced an unprecedented boom in recent years. Every third e-bike/pedelec in Europe was sold in Germany, totaling 850,000 e-bikes by the year 2018. This is a clear sign that a very large part of the future of biking will also be in e-bikes. There are various reasons for this development. The demographic change, the most recent movement trend and the increasing urbanization are only a few of the reasons why more and more bikers are

choosing the support of an electric motor. Much more important than the reasons why is the question of how communities, cities or regions/destinations deal with this development. Even though e-bikes and conventional bikes seem to be quiet similar at first glance, the needs of the individual users differ. The performance data of e-bikes alone, for example, place new demands on the dimensions of bike infrastructures. These special requirements are addressed by specialized e-bike trails for both urban and off-road use.

## E-bike trails offer the following benefits

- The demand for longer trails with more incline can be addressed specifically
- Cost-effective planning of infrastructures particularly for E-Bikes (charging stations, rental, courses, workshop etc.)
- Environmentally-friendly concept of planning and construction (e.g. abrasion-resistant trails, in order to keep up with the increasing performance of the e-bikes)
- Channeling and safeguarding of sporting activities
- A useful addition to trails in addition to ascent aids in order to serve another target group and generate added value.

## Characteristics

### target group

- Tour; Marathon/Cross-Country
- All Mountain/Enduro
- Freeride/Downhill
- Target group zero

### difficulty level



### construction measures



### current costs



### surface

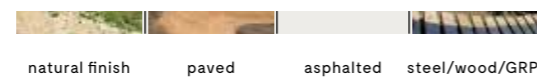

### cost per square meter



# Potentials of EMTB

The e-bike is and will continue to remain a big trend in biking primarily presenting a large sales market for bicycle manufacturers. But how does this trend affect the Summer tourism and its value chain?

By 2030, the predicted goal for mountain biking is to achieve a 20% market share of summer tourism in the European Alpine region, the Alpine foothills

and the low mountain ranges. The prerequisites for this are in place and the E-MTB has a decisive role to play in this development. By having a lower threshold thanks to a lower physical demand on the users (muscle & motor power) and therefore attracting a broader target group, the E-MTB is the lever for a broader acceptance of mountain biking in general majority of the population.

## 3 Who "benefits" from the potential of EMTB? factors for a broader market acceptance

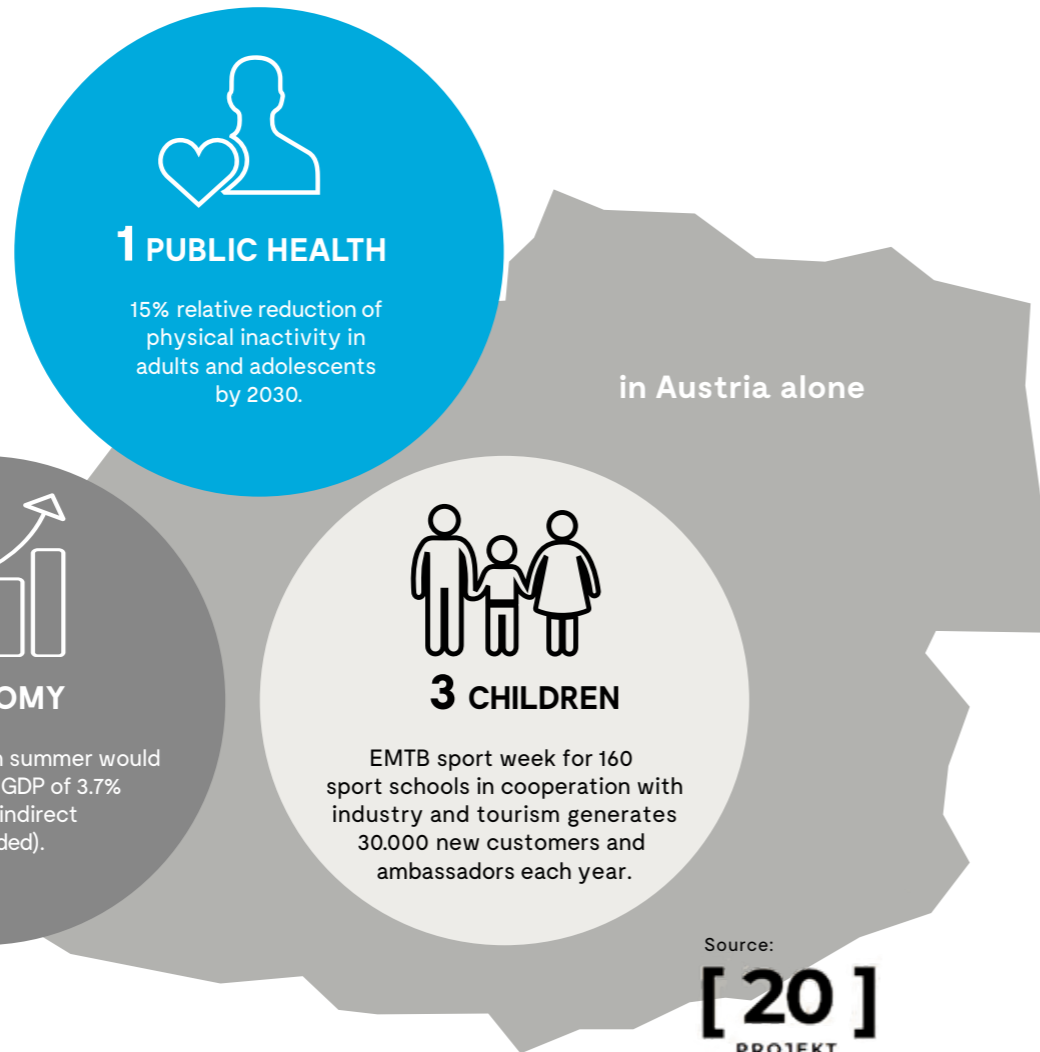

# Bosch eTrail Parcour

Kusterdingen, Germany

In 2018, we planned and implemented a test site for Bosch eBike Systems at the development site in the town of Kusterdingen. To meet the requirements of e-bike trails, the facility was designed in such a way that, compared to "regular" bike trails. It contains many "uphill passages" and offers realistic test conditions for the development of e-bikes. The test riders will find a mixture of artificial and natural obstacles divided into three levels of difficulty expanding over multiple track lengths.



# Freeride trail

Steep sections, jumps, steep bends, natural and man-made sections. The freeride trail is not easy to be classified but is rather extremely versatile. This is precisely the principle of "freeriding", to be able to use every terrain possible, to "play" with it and to conquer its descent by bike. Therefore, freeride trails are naturally classified as medium

to difficult trails and require extensive construction work due to the wide variety of demands. There are no limits to the creativity of the course layout using drops, jumps, North Shore elements, stone fields etc., attracting many different types of mountain bikers.



## Characteristics

### target group

- All Mountain/Enduro
- Freeride/Downhill

### current costs



### difficulty level



### surface



### construction measures



### cost per square meter



# Jump trail

Originally located in the bike park, this trail is known for its perfectly coordinated sequence of jumps with variable levels of difficulty. The jumps can also be built to be rolled over or with so-called “chicken lines”, allowing advanced riders and professionals as well as beginners to be addressed. The jump trail is often one of the main reasons for people visiting bike parks and is typical for modern bike facilities. This also makes it a media-effective instrument that attracts numerous spectators with its exciting jumps and that is perfectly suited for show events. Professionally designed jump trails have become a crowd-puller. Thanks to an ingenious design of jumps, safety does not fall by the wayside.



## Characteristics

### target group

- All Mountain/Enduro
- Freeride/Downhill

### current costs



### difficulty level



### surface

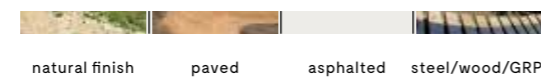

### construction measures



### cost per square meter



## Bike park Oberammergau jump trail

Oberammergau, Germany

The region surrounding the town of Oberammergau is ideal for all kinds of biking. Therefore, a bike park is a must. Local initiators have advocated for the (re-)opening of the bike park "Kobelsattel" located on the mountain Kobelsattel in Bavaria and thereby hired us to design and build the shell of a flowline (approx. 1,200 m) and a jump trail (approx. 400 m). Due to this extension, the bike park Oberammergau offers a wide range of trails that appeals to all athletes, from the first-time bike park user to the professional alike.



## "Bikewelt" Schöneck- jump trail

Schöneck, Germany

Since 2009, the flow trail "Bikewelt" in Schöneck has been home to gravity and speed fans with its two downhill trails. Due to the increasing demand for MTB and the desire for a year-round complete facility for a broad target group, the bike park was expanded in autumn. This included building three more trails and the expansion of the existing downhill trails. We were responsible for the planning, development and construction of the existing and new trails. The new concept allowing all trails to be ridden as a combination of flowline, dirt jumps, and downhill trails ensures that the needs of all downhill mountain bikers are met in the most compact space.





# Single trail

There hardly is any other trail that can be used as versatilely and built as sustainably as the single trail. It is a narrow path that is rarely wider than 80 cm, that is only ridden one way and that runs through a wide variety of landscapes with many bends and levels of difficulty. It doesn't matter whether the trail leads over sand, forest soil or gravel. The single trail is traditionally left in its natural state and in the medium to higher level of difficulty it contains obstacles such as roots, stones and steps. No matter whether it is built in

a bike park, as a connection between two villages or as an alternative to a planned forest road, the single trail is an efficient, sustainable way to build a bike track without harming the environment with heavy construction machines. In case of high traffic and/or frequent use in bad weather, as well as in case of trails running through steeper terrain, the single trail in its natural way of construction is usually very high-maintenance. Meaning that over the lifetime of the trail, significant follow-up costs to the favorable initial costs can be expected.

## Characteristics

### target group

- Tour; Marathon/Cross-Country
- All Mountain/Enduro
- Freeride/Downhill
- Target group zero

### difficulty level



### construction measures



### current costs



### surface



### cost per square meter



## Zillertal Arena Trail

### Zell, Austria

Covering around 5.5 km, the trail overcomes approximately 700 meters of descent. The "Single Trail" was developed as a diverse and playful freeride or enduro trail, primarily addressing beginners and advanced riders due to its rollable elements. By integrating typical pump track elements, especially waves and banked turns, the "Single Trail" also offers more experienced riders excitement, challenges and various combination possibilities, without losing the focus on beginners.



Bike

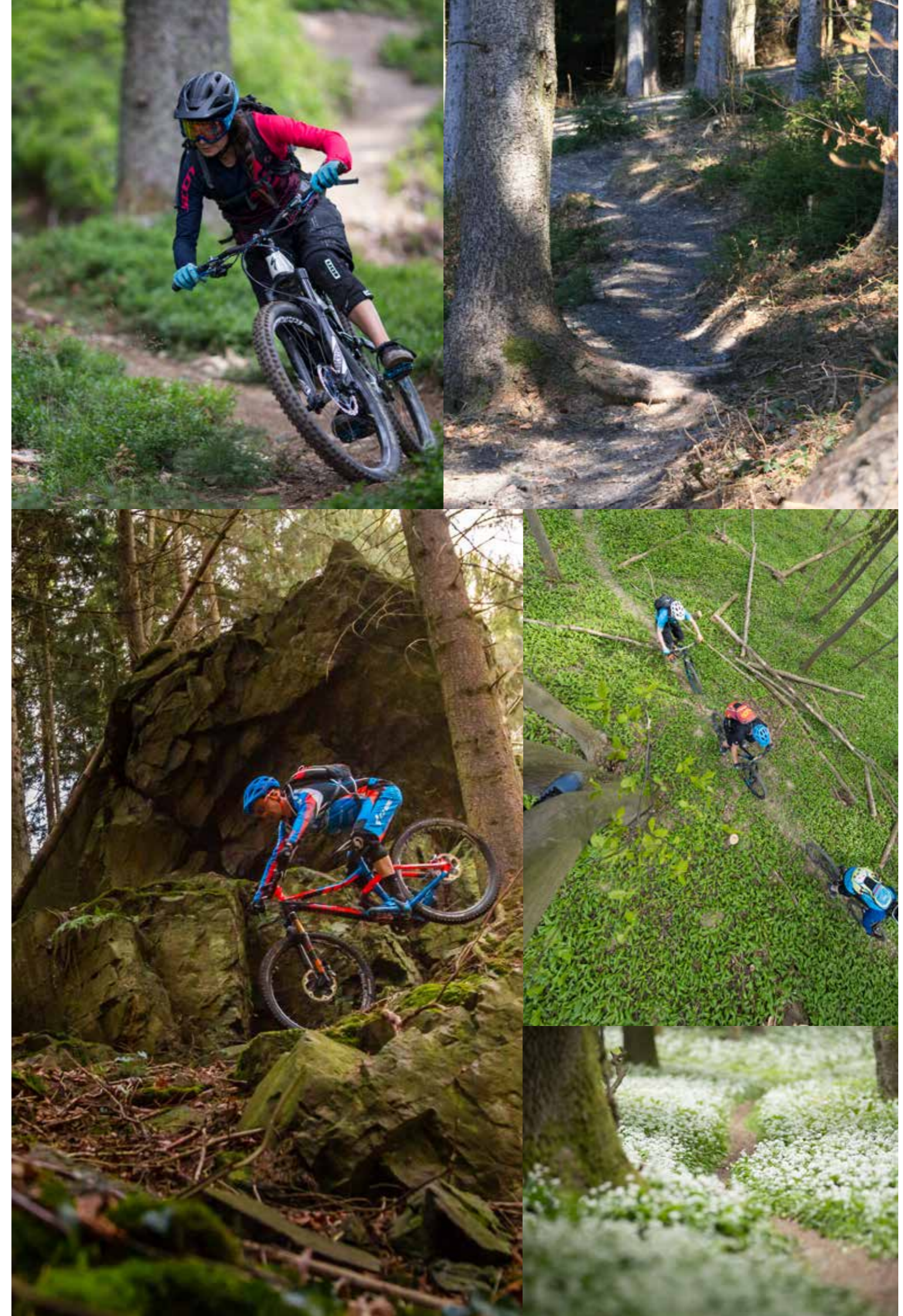

# Downhill trail

Calling it the premier class of mountain biking might be a bit too much, but the downhill trail is definitely one of the most spectacular types of tracks. Following the basic principle of downhill riding, a challenging route is to be tackled as quickly as possible. The most important criteria for this type of course is the skillful combination of both natural (e.g. stone fields, root sections) and artificial elements (e.g. wooden obstacles, extended drops) in order to create a demanding and action-packed riding experience. As a result, downhill trails are one of the most popular media formats in mountain biking. Even amateurs riders attract large numbers of visitors at downhill competitions. Thanks to the natural character of the track, the effort required for construction is moderate, but the requirements for the terrain are very specific and maintenance is known to be extensive.

## Characteristics

### target group

→ Freeride/Downhill

### difficulty level



### construction measures



### current costs



### surface



### cost per square meter

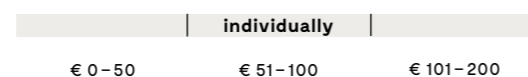

# North Shore Elements

Nowadays, North Shore elements can be found on numerous trails and in every well-planned bike park. These wooden constructions were first built in Canada to overcome rugged terrain without major problems. This principle was adopted from the "North Shore Mountains" and brought over to Europe where it is also highly appreciated. Meanwhile, North Shore elements are no longer used only for crossing rugged terrain, but as artificial bridges and the construction of waves, jumps and bends adding extra fun and challenge to the trails. Since the elements can be adjusted to suit

beginners as well as advanced and professional riders, they enjoy great popularity and are used by many athletes.

In addition to the technical advantages, the use of North Shore elements offers constructional advantages:

- **Safety zones can be bypassed**
- **Wet areas can be integrated into the route and passed over**



## Characteristics

### target group

- Tour; Marathon/Cross-Country
- All Mountain/Enduro
- Freeride/Downhill
- Target group zero

### difficulty level



### construction measures



### current costs



### surface



### cost per square meter

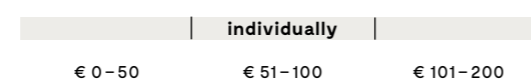

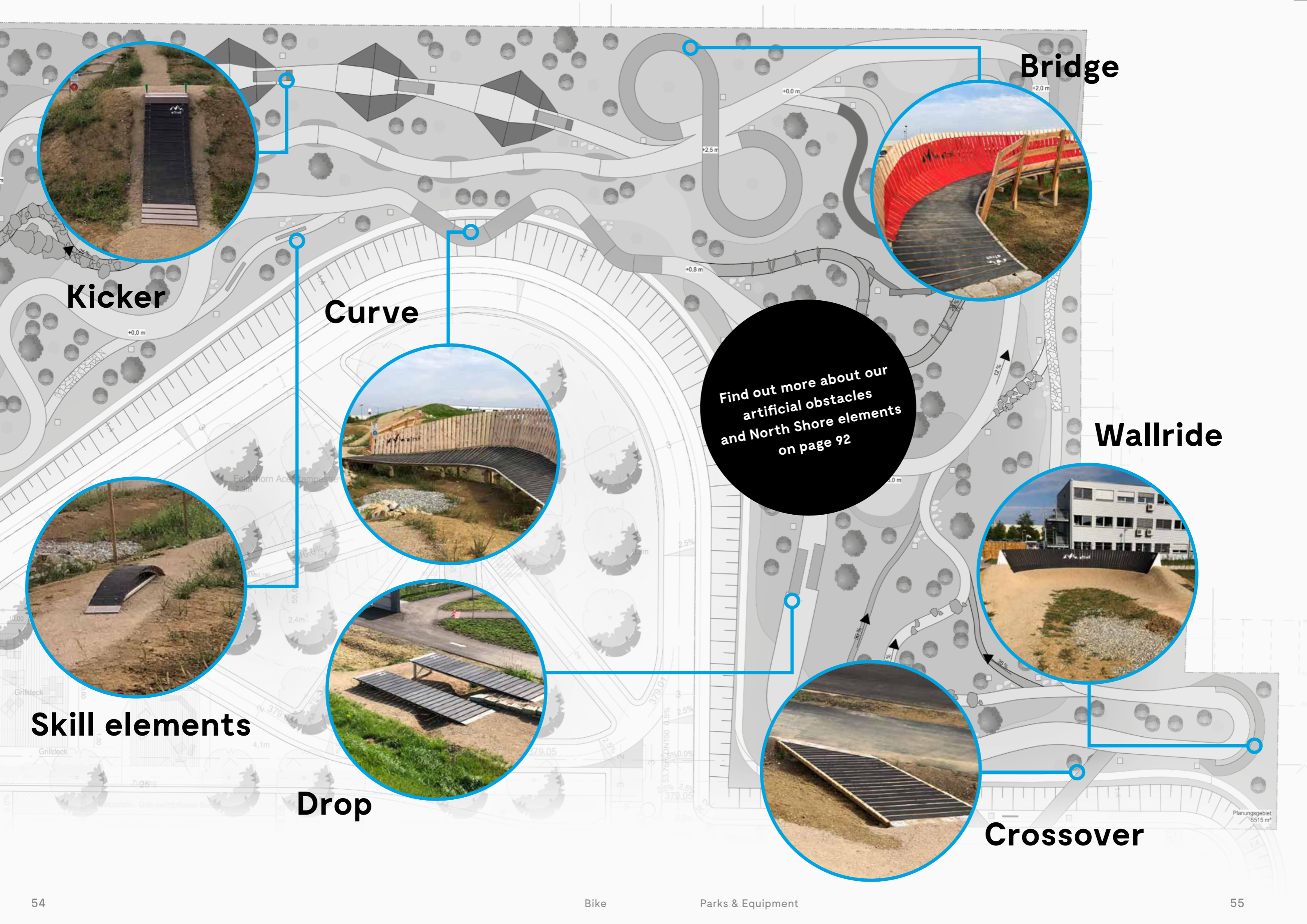

**Bridge**

**Kicker**

**Curve**

**Wallride**

Find out more about our artificial obstacles and North Shore elements on page 92

**Skill elements**

**Drop**

**Crossover**



“Stationary, highly frequented and attractive —bike facilities, as a central point of contact for the modern promotion of movement.”

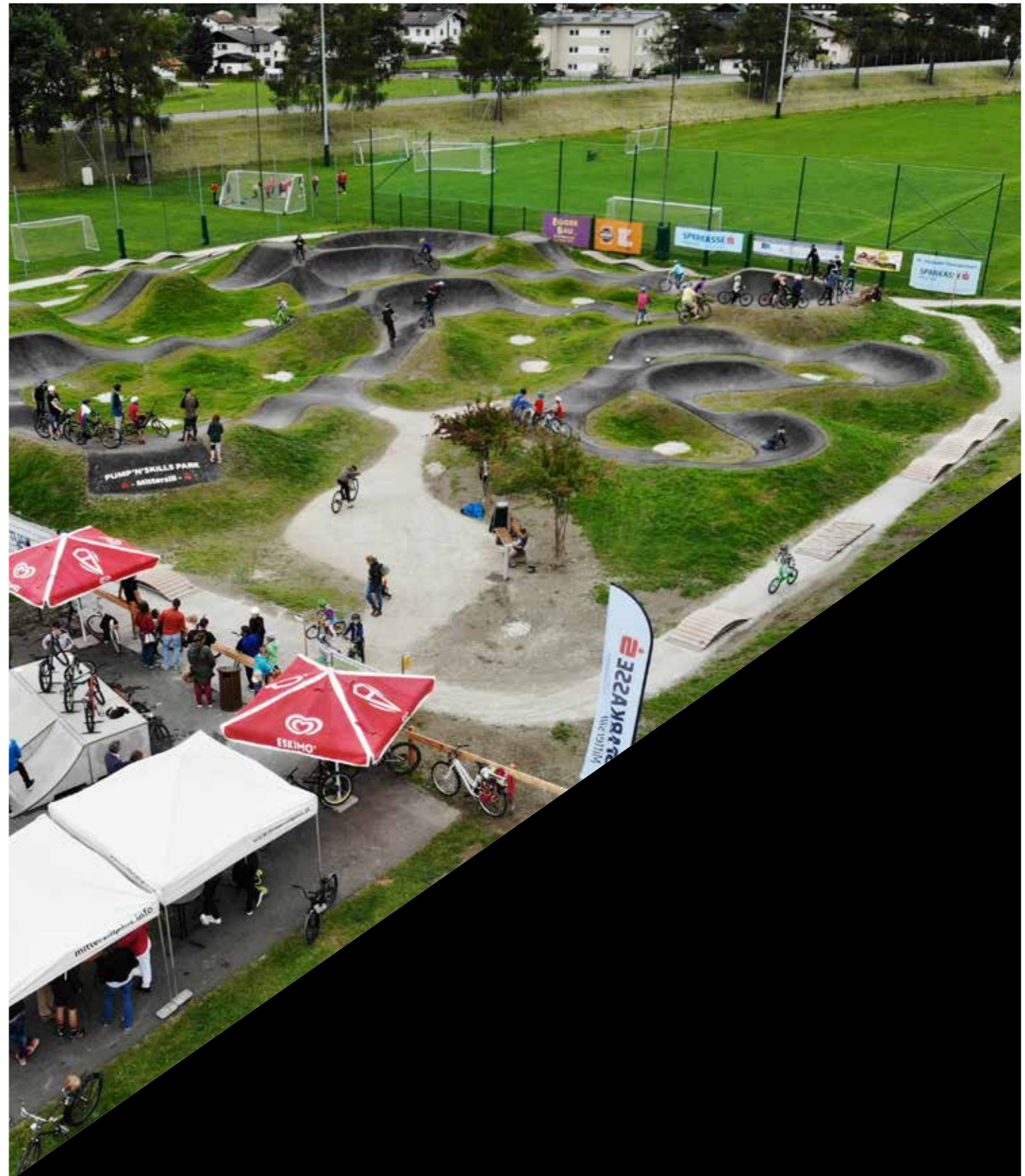
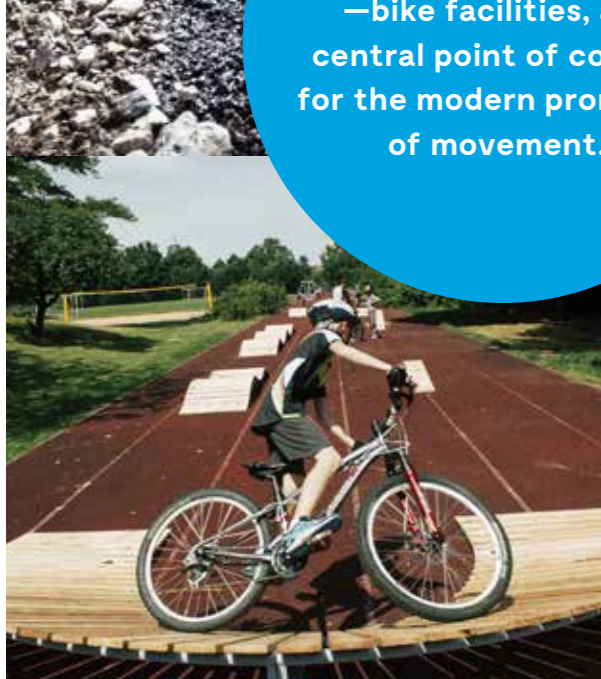

# FACILITIES

# Target groups—Facilities

Today, 75% of the European population lives in cities, and in 2018 76% of the population in Germany alone were cyclists. In addition, there is an extremely large and heterogeneous group of athletes enjoying different types of roller sports who are also using many of the bike facilities. This observation alone illustrates the incredible potential of bike sports facilities. In order to utilize this great potential and effectively address the extremely broad target group associated with it, targeted segmentation is required. Therefore, we have clearly divided the entire target user groups of bike facilities:

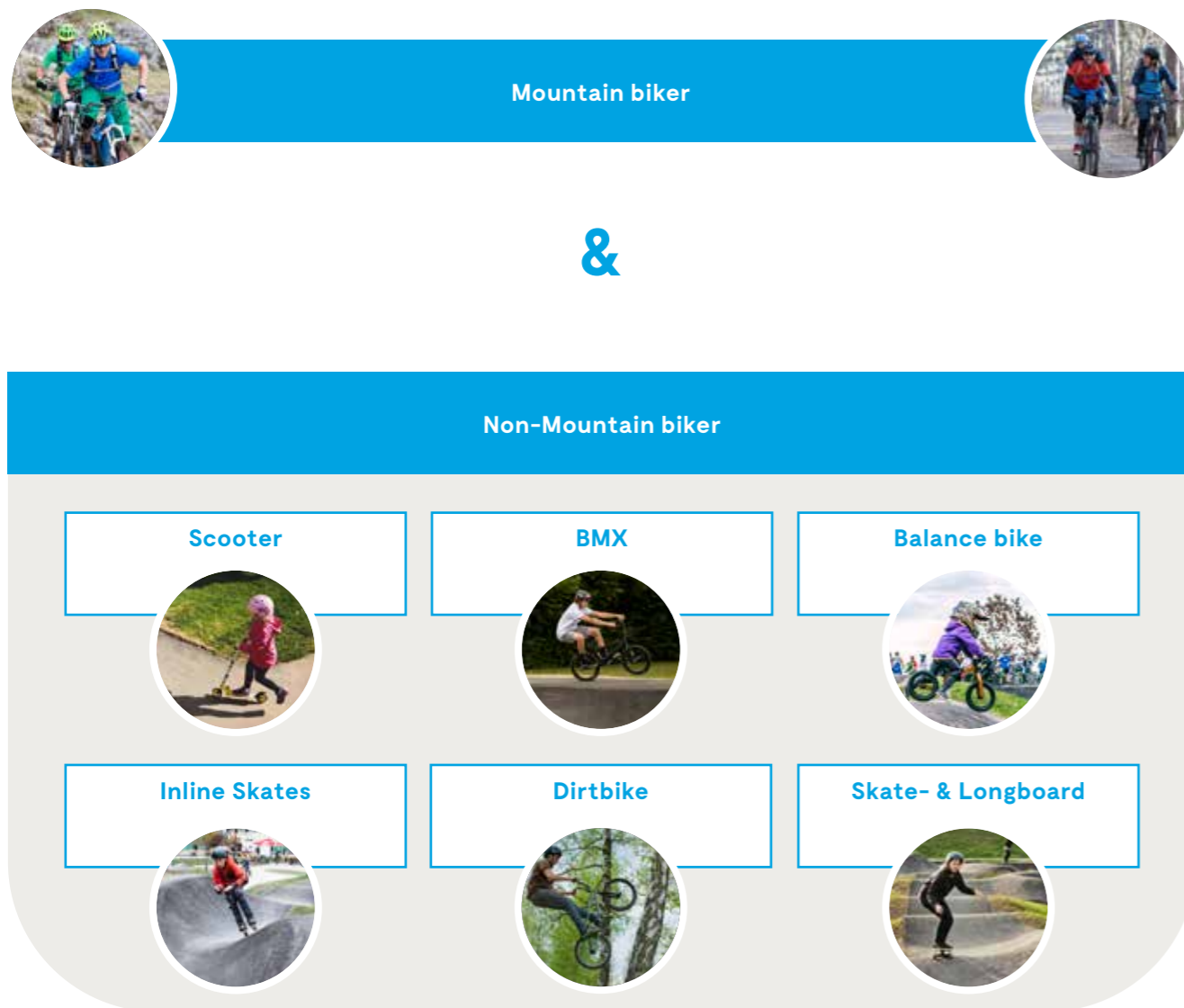

Bike sports are versatile. In order to simplify the overview of such individual products, we have classified the most important types of trails / facilities according to two decisive measurements—the difficulty and the breadth of the target group. This allows you to estimate the potential of each system at a glance.

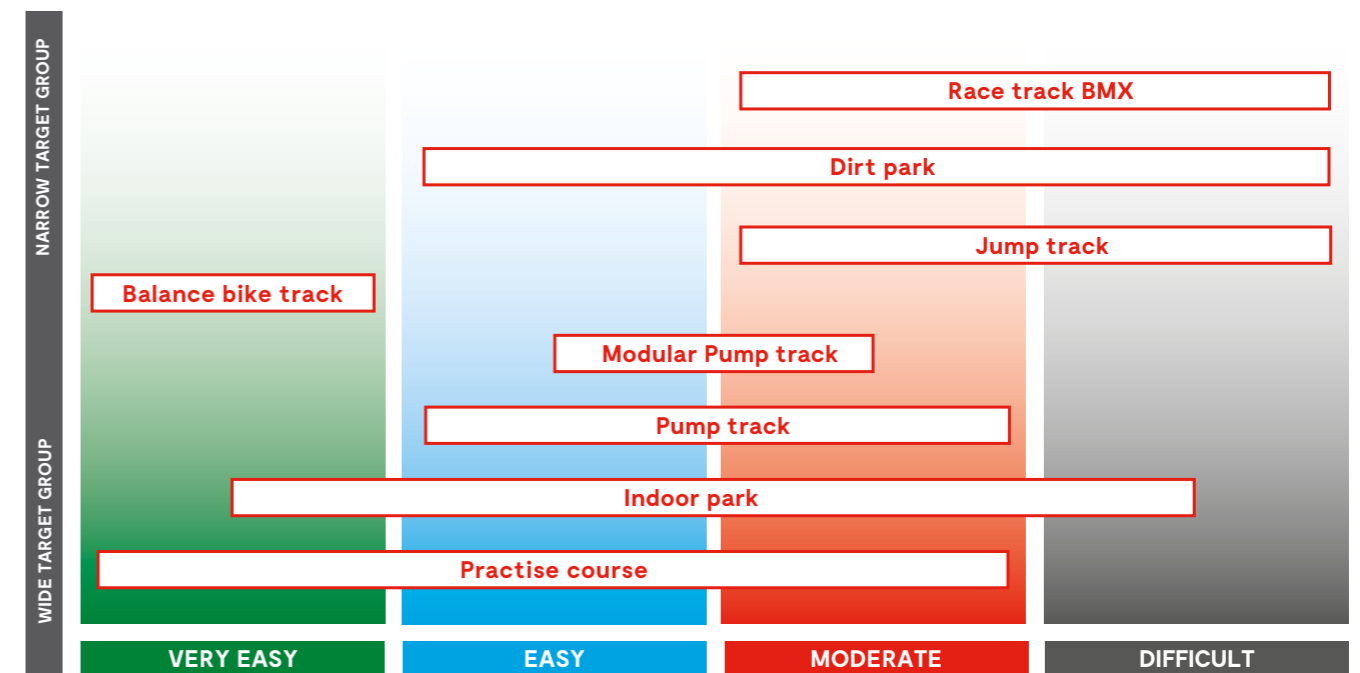

# Pump track

## Example facility: Pump 'n Skills Area Mittersill

Best practice for a pump track—the Pump 'n Skills Area in the town of Mittersill. This track shows how flexibly a pump track can be built and adapted to local conditions.





What is particularly striking, however, is the target-group-specific subdivision of the facility. A well-designed pump track installation can accommodate all user preferences for sports equipment, difficulty and speed.

Opened in  
August 2018

2500 m<sup>2</sup> Built surface area      **38,449 km** covered

**379,286** laps completed

550 m<sup>2</sup> asphalt surface

-  balance bike track
-  pump track
-  jump track
-  skills obstacles

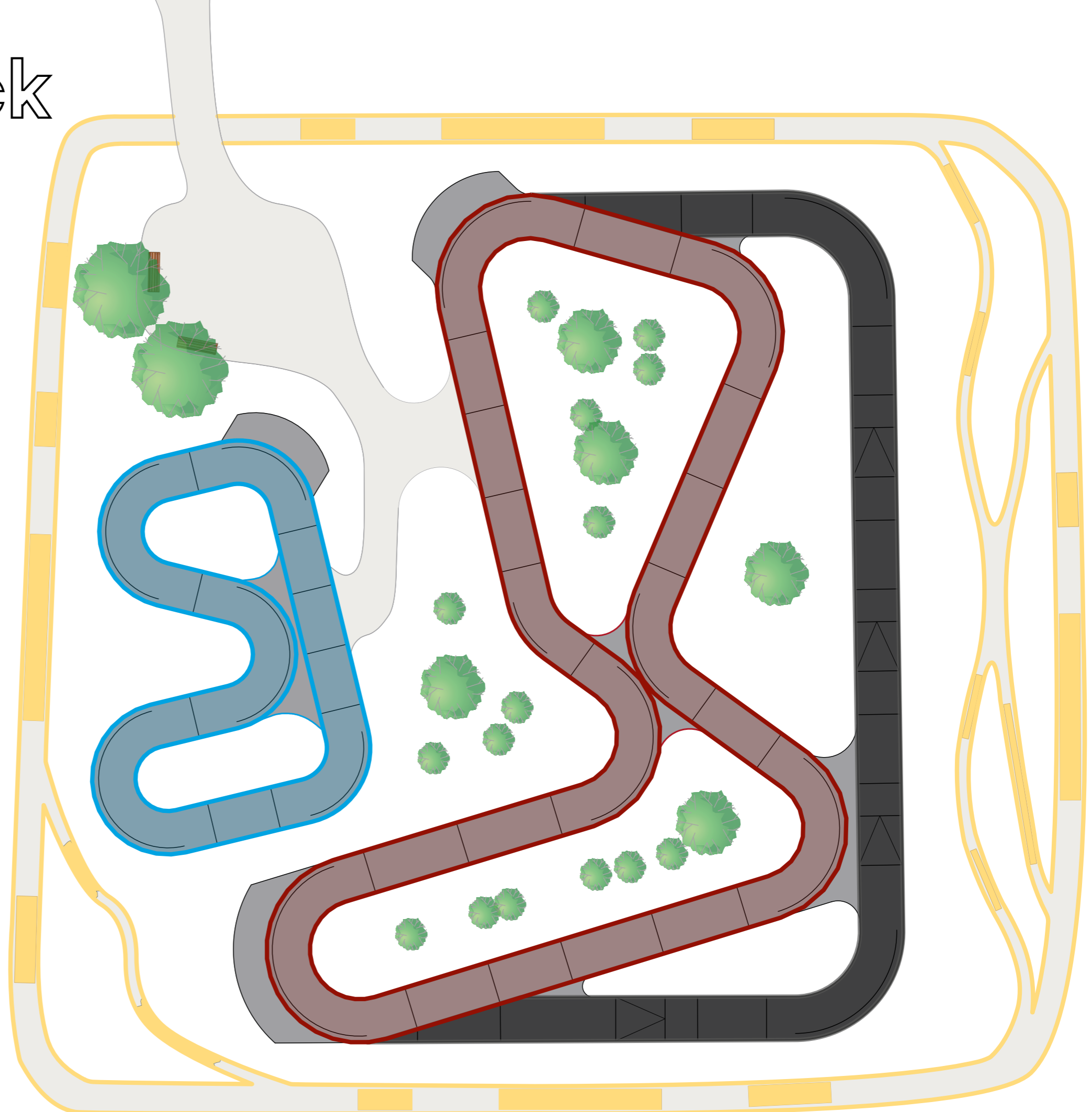

# Pump track

If there is a bike park literally providing endless fun then it is the pump track. The aim is to ride the pump track with its waves, curves and jumps in an infinite loop through dynamic up and down movements—the so-called “pumping”—and to generate speed without pedaling or pushing. Once this principle is taken into account, there are no limits on how to design a park. Therefore, countless forms of pump tracks can be built. The layout can be individually tailored to the terrain and, thanks to its similarity to parks, it blends perfectly into the modern cityscape. As an urban sporting facility, the pump track also impresses with its high level of safety. Since the riding ability determines

the maximum speed, this type of facility is considered very safe and has the same hazard rating as children’s playgrounds. If the pump track is paved, it is not only very low maintenance and safe from vandalism, but also becomes accessible for many types of users such as skateboarders, longboarders, scooter riders, inline skaters and even people in a wheelchair. Summarizing these aspects, it becomes clear that the pump track is not solely a simple facility for bike sports, but the most versatile multi-sport system for roller sports available to date. Do decide to buy a pump track and therefore promote “exercise” in your community.



## Characteristics

### target group

- Mountain bike
- Balance bike
- BMX/Dirtbike
- Target group zero
- Inline skates
- Scooter
- Skate- & Longboard

### difficulty level



### construction measures



### current costs



### surface

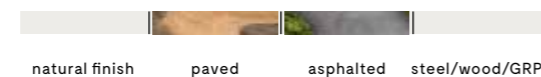

### cost per square meter

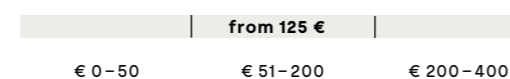



# Balance bike track

The balance bike track is the “little brother” of the pump track being an ideal, playful introduction to cycling for children from about 2 years of age. The circuit with its low waves is the perfect and safe place for small children to train and further develop their coordination skills on balance bikes. In this

context, they not only improve their body awareness, but also develop an initial understanding of how to behave in groups. From a construction point of view, the wheel track is particularly attractive due to its relatively small size, which means that it can be integrated into practically any location.



## Characteristics

### target group

→ Balance bike

### current costs

€ low    € medium    € extensive

### difficulty level

very simple    easy    medium    difficult

### surface

natural finish    paved    asphalted    steel/wood/GRP

### construction measures

low    medium    extensive

### cost per square meter

from 100 €  
€ 0-50    € 51-200    € 200-400

# Jump track

This part of a pump track is characterized by a perfectly coordinated sequence of jumps with variable levels of difficulty. The jumps are usually built in such a way that they can be rolled over, meaning that not only advanced riders and professionals can be attracted as a target group but also beginners. For many young riders, the

jump track is often one of the highlights of pump track facilities. With its exciting jumps this media-effective instrument attracts numerous spectators and is perfectly suited for show events. Thanks to a sophisticated design of jumps, safety does not fall by the wayside.



## Characteristics

### target group

- Mountain biker
- BMX/Dirtbike
- Scooter

### difficulty level



### construction measures

- low (represented by a hammer icon)
- medium (represented by a pickaxe icon)
- extensive (represented by a pickaxe icon)

### current costs



### surface

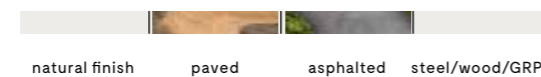

### cost per square meter



## Pump track Wals-Siezenheim

Wals-Siezenheim, Austria

Thanks to the joint efforts of the municipality of Wals-Siezenheim and the local bike club, the RC Wals-Siezenheim, the “largest village in Austria” now also has the largest pump track in Austria.

Covering an area of 900 m<sup>2</sup>, the pump track offers two mirrored tracks and a jump line. Perfect for beginners, but also for professionals and every other rider in between who would like to participate in a head to head race.



## Pump track Groß-Umstadt

Groß-Umstadt, Germany

A pump track which covering over 1.300 m<sup>2</sup> whilst providing a handicapped accessible practice track for wheelchair users and balance bikes sounds too good to be true? That's not the case in Groß-Umstadt in Hesse. Here, another member of the Schneestern asphalt pump track community has been exciting the local bike, skate and BMX scene with banked turns and waves since May 2017.



Bike

## Pump track Füssen

Füssen, Germany

The two pump tracks in Füssen are part of a 4,400 m<sup>2</sup> skate and bike park. The main goal was to build a facility that is accessible to all levels whilst providing fun for all abilities. Both pump tracks enclose a skate park (bowl, street plaza and mini ramp), with the smaller track consisting of a single loop with two banked turns and two doubles per direction—simply perfect for beginners. The larger pump track has an outer dimension of 43 x 24 m and is a good combination of being demanding for advanced riders but still challenging for experts. This pump track has several different banked turns, doubles and transfer jumps that require flow and creativity. Just the right place for your enthusiastic bikers!



Parks & Equipment

## Pump n' Skills Area Mittersill

Mittersill, Austria

A place of modernity and tradition in front of an impressive panorama. Here, there is no better fit than a modern sports facility in a park designed for several generations. Located right next to a campsite, the 400 m<sup>2</sup> pump track has clearly upgraded the existing leisure facilities. The pump track in the town of Lermoos is perfectly complemented by the adjacent adventure playground and is the ideal destination for a fun and active family holiday in the surrounding area. The pump track fits the local tourism concept perfectly and supports the guidance of its guests.



69

## Pump track Lermoos

Lermoos, Austria

A place of modernity and tradition in front of an impressive panorama. Here, there is no better fit than a modern sports facility in a park designed for several generations. Located right next to a campsite, the 400 m<sup>2</sup> pump track has clearly upgraded the existing leisure facilities. The pump track in the town of Lermoos is perfectly complemented by the adjacent adventure playground and is the ideal destination for a fun and active family holiday in the surrounding area. The pump track fits the local tourism concept perfectly and supports the guidance of its guests.



## Pump track Pegnitz

Pegnitz, Germany

There couldn't be a better place for an asphalt pump track in Pegnitz, than right next to a sports school. 220 m<sup>2</sup> of particularly smooth asphalt for low rolling friction and low-noise riding make both riders and residents happy. With a length of 102 m, this small park (S) offers an easy introduction into the world of pump tracks. With a nearby skate park currently under construction, Pegnitz will have its own little action sports paradise.



Bike

## Pump track Nupaky

Nupaky, Czech Republic

A placid Czech town with just 1800 inhabitants. Nupaky, south of Prague, is probably not the first place where you would expect a new asphalt pump track from Schneestern, and yet our partners for the Czech and Slovakian market Filip Majkus and Michal Marosi were able to inspire the municipality for their first pump track project. This was not only thanks to the combination of our know-how, the experience of Filip and influence of Michal as a veteran of the Czech bike scene, but also because the Pumptrack is a future-proof multisport facility with a wide user group and a long durability. The final result is an 860 m<sup>2</sup> pump track consisting of a kids' track with a length of 25 meters and the main track with 95 meters. The Schneestern team for the Czech and Slovakian market installed 95 tonnes of asphalt in just 19 days and with that laying the foundation for the upcoming pump track euphoria in the Czech Republic and Slovakia.



Parks & Equipment

## Schachermayer pump track Linz

Linz, Austria

If you like to hang out with your friends, but also appreciate sporting competition, Linz is the place to be. Here there is a pump track on the premises of Schachermayer-Großhandels-gesellschaft m.b.H. The health and cohesion of the more than 2000 employees is the main concern of the managing directors in this project. The asphalt pump track, with its future-oriented design, is a perfect match for the company. The pump track with floodlights consists of two mirrored tracks, which lie, in a butterfly shape, next to each other. This setup invites you to a little race and guarantees that the pump track is fun even when there is a lot going on. That even the youngest children do not have to be bored and can practice for the long distance, an additional blance bike track was created.



71

# The pump track as a communal sport facility

Looking at municipalities and sport facilities in Germany and Austria, many similarities can be seen: Under high pressure to adapt and change, both must face a variety of challenges such as demographic change, changes in educational policies, shifts in sport interests, structural crises in public financing, etc. The logical conclusion is that both areas support each other in solving these problems.

The asphalt pump track manages this balancing act as it is a future-oriented sport facility, a so-called sports ground 2.0.



Modern sport facilities focus mainly on topics such as attractiveness of the location, education, health and social integration. Thereby the requirements for a sports ground 2.0 become clear:

It must be sustainable/long-lasting, offer a high social added value (a good social return) and at the same time be versatile and attractive for as broad a user group as possible.

Municipalities need a long-term location for many types of sport, instead of multiple facilities accommodating only one type of sport at a time.

The pump track meets exactly these requirements:

- **Variety of user groups: mountainbikes, non-mountainbikes, skate & longboard, BMX, scooters, balance bikes, inline skates.**
- **Asphalt pump tracks are low-maintenance, safe from vandalism and therefore extremely durable as municipal sport facilities.**

Riding a pump track is simple, intuitive and fun for all ages. Various rolling sports can be carried out across generations on one course, regardless of ability and riding style. The pump track serves as a multipurpose sport facility for municipalities and is therefore the best way to promote physical activity.

The motto is:

**“Turn off your phone, drop the burger and hop onto the pump track”**

## Pump tracks as a cure for social and health related problems in young people

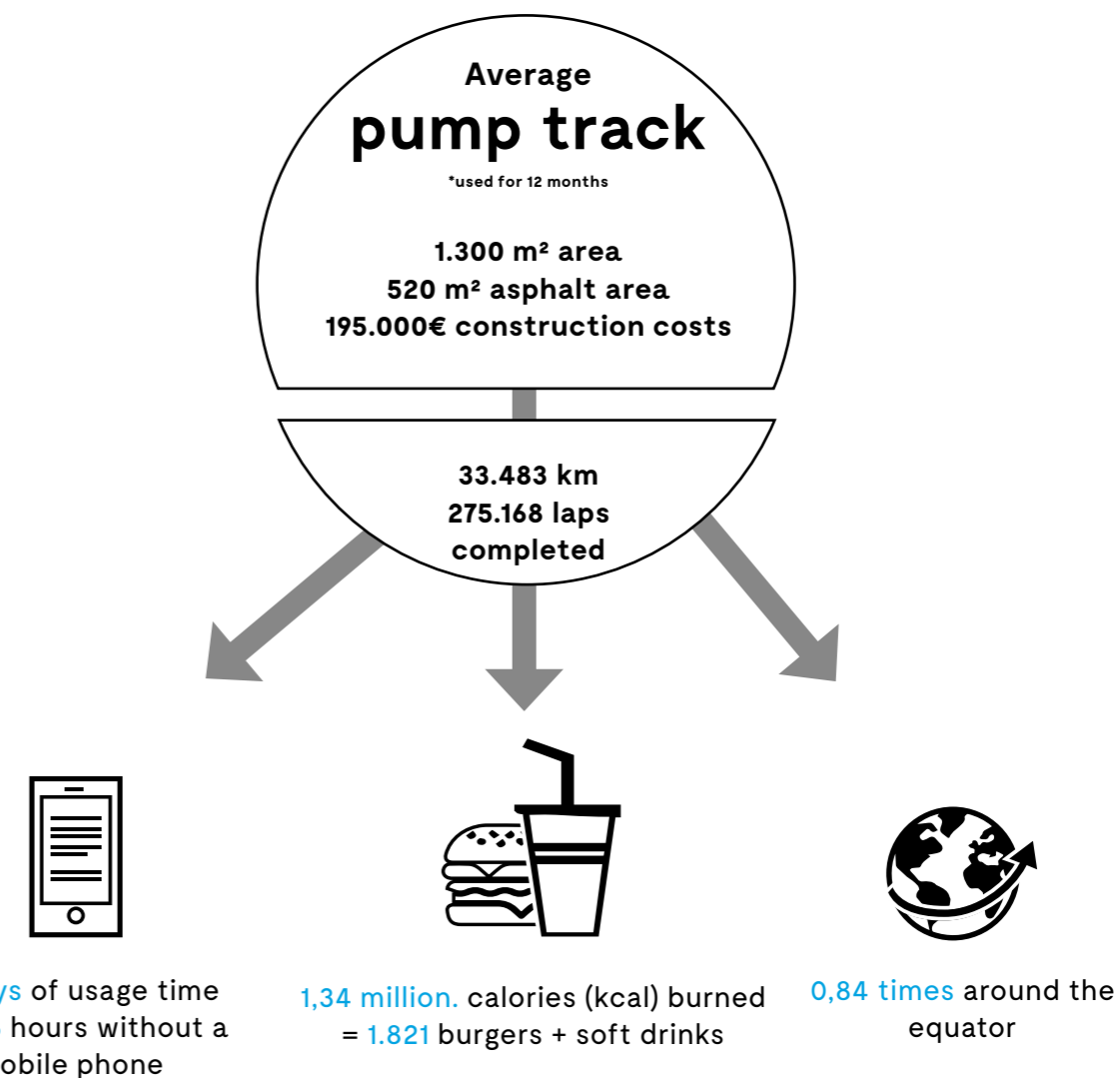

Riding a pump track is a sport that encourages movement, which can be easily proven thanks to the way it is constructed. Modern counting systems show the great influence such a sport facility has on the users' sport motivation.



## The combination of movement, fun, safety and the variety of user groups makes these facilities unique

From a planning point of view for municipal sport facilities, there are significant advantages regarding the pump track

- Diversity of user groups:
  - Mountain biker
  - Non-Mountain biker
  - Skate & long board
  - BMX
  - Scooter
  - Balance bikes
  - Inline skates
  - Wheelchair
- Safety:
 

According to the Swiss Council for Accident Prevention, pump tracks are classified as “blue” sport facilities equivalent to children’s play-grounds.
- Investment:
 

With costs starting from 125€/m<sup>2</sup>, the total investment for the pump track is far below the average for classic sport facilities such as soccer fields. In addition, a pump track in its asphalted version (300€/m<sup>2</sup>) is very durable and extremely low-maintenance, resulting in almost no running maintenance costs.



Educational institutions such as kindergartens, schools and universities benefit from the pump track

- Creation of a modern and multifunctional facility.
- Movement is actively and unconventionally promoted.
- Sport activities are consciously offered and encouraged.
- Increasing the attractiveness of educational institutions.
- Possibility of combining study and recreational time.
- Place of encounter and personal fulfilment.

# Target groups of pump tracks

It is not without reason that the asphalt pump track is referred to as a multifunctional sport facility. Due to the characteristics of the facility, an extremely broad target group is reached, making it the perfect prerequisite for an urban / municipal sport facility.



**Mountain bike**



**Skateboard**



**BMX**



**Scooter**



**Dirtbike**



**Inline Skates**



**Balance Bike**



**Wheelchair**

# Asphalt pump track

recommended

The use of asphalt as a track surface provides the ultimate all-purpose solution for multi-functional roller sports facilities. Particularly in urban areas, asphalt surfacing has become an integral part of modern concepts developed for sport facilities. Compared to natural and paved facilities, the higher acquisition costs (375€/m<sup>2</sup>) are put into perspective by the crucial advantages of the asphalted versions. Especially when longevity and minimal maintenance are vital criteria, asphalt is the only construction material to be considered.

## ADVANTAGES:

- Low maintenance
- Safe from vandalism and durable
- Multifunctional for many roller sports
- Clean and urban look
- Highest traction and low rolling resistance
- Rideability even in wet conditions
- Fast-drying
- Frost-resistant
- Color design possible
- Less expensive than constructions using concrete
- Design/form independent of area
- Measurability through an integrated counting system

# No noise related problems with asphalt pump tracks

Noise pollution is a major concern when it comes to sport facilities in public spaces and especially for those that are specifically designed for a young target group. In this respect, too, the asphalt pump track scores highly due to its low noise pollution.

## Noise sources and their sound power (SWL)

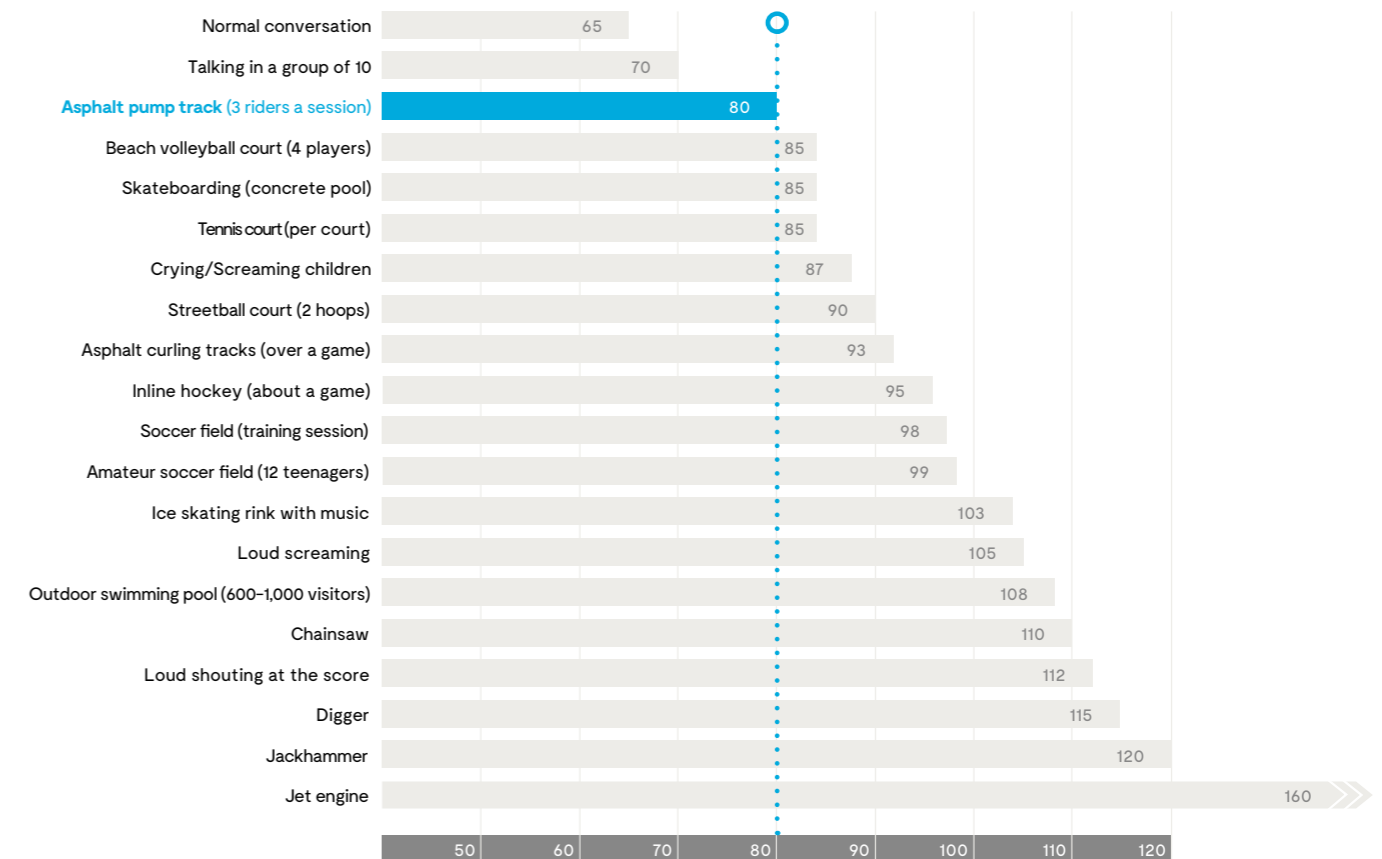

# Examples of asphalt facilities

## Balance bike / pump track

Location: playground, kindergarten, day nursery, school, park, residential complex, shopping center, hotel

Area: from 250 m<sup>2</sup>

Asphalt area: 100-250 m<sup>2</sup>

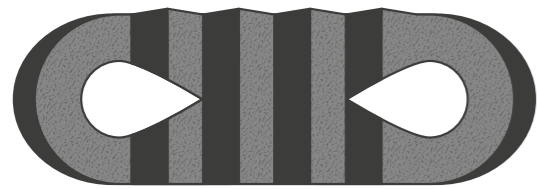

XS

## Pump track

Location: playground, school, park, residential complex, small municipality, shopping center, hotel

Area: from 625 m<sup>2</sup>

Asphalt area: 250-500 m<sup>2</sup>

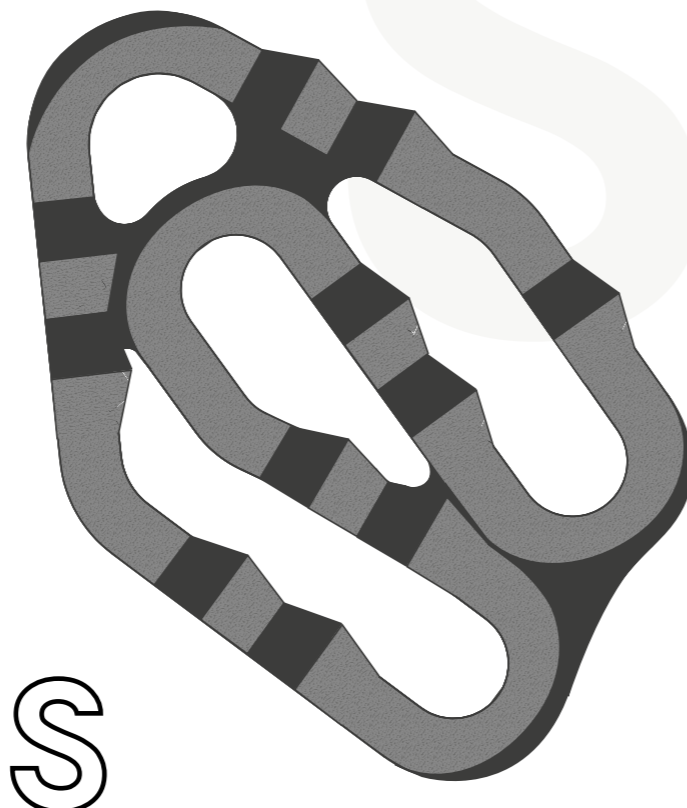

S

M

## Pump track

Location: playground, school, park, residential complex, hotel, municipality, small town, leisure park, shopping center,

Area: from 1250 m<sup>2</sup>

Asphalt area: 500-1,000 m<sup>2</sup>

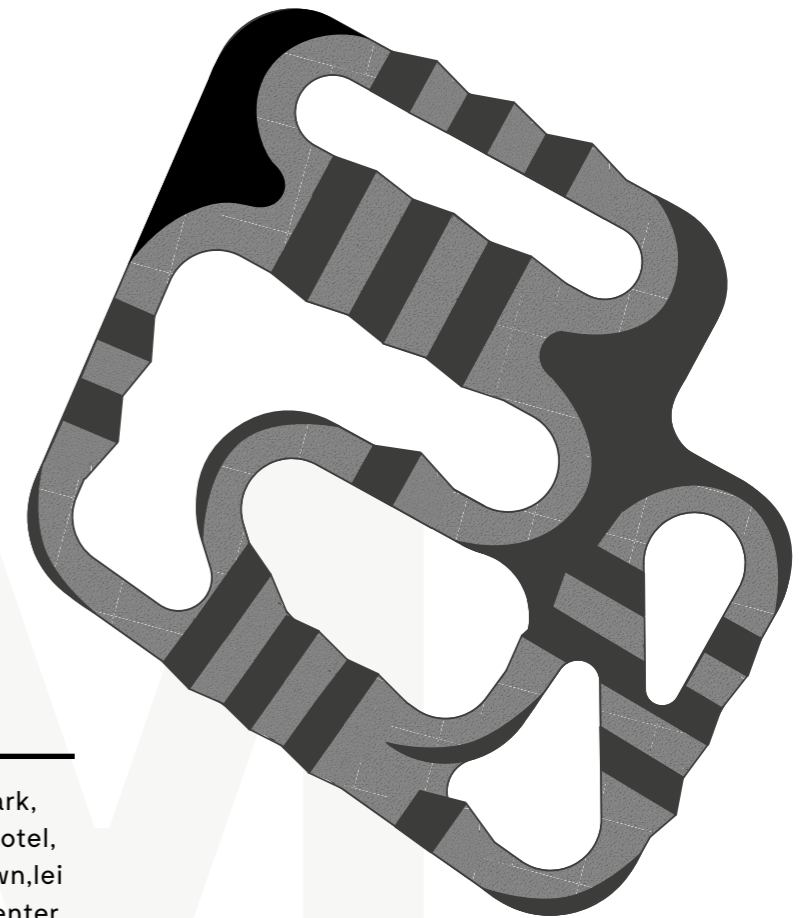





## Pump track

Location: Park, large municipality, town, leisure park, training facility, hotel  
 Area: from 2500 m<sup>2</sup>  
 Asphalt area: 1.000–2.000 m<sup>2</sup>

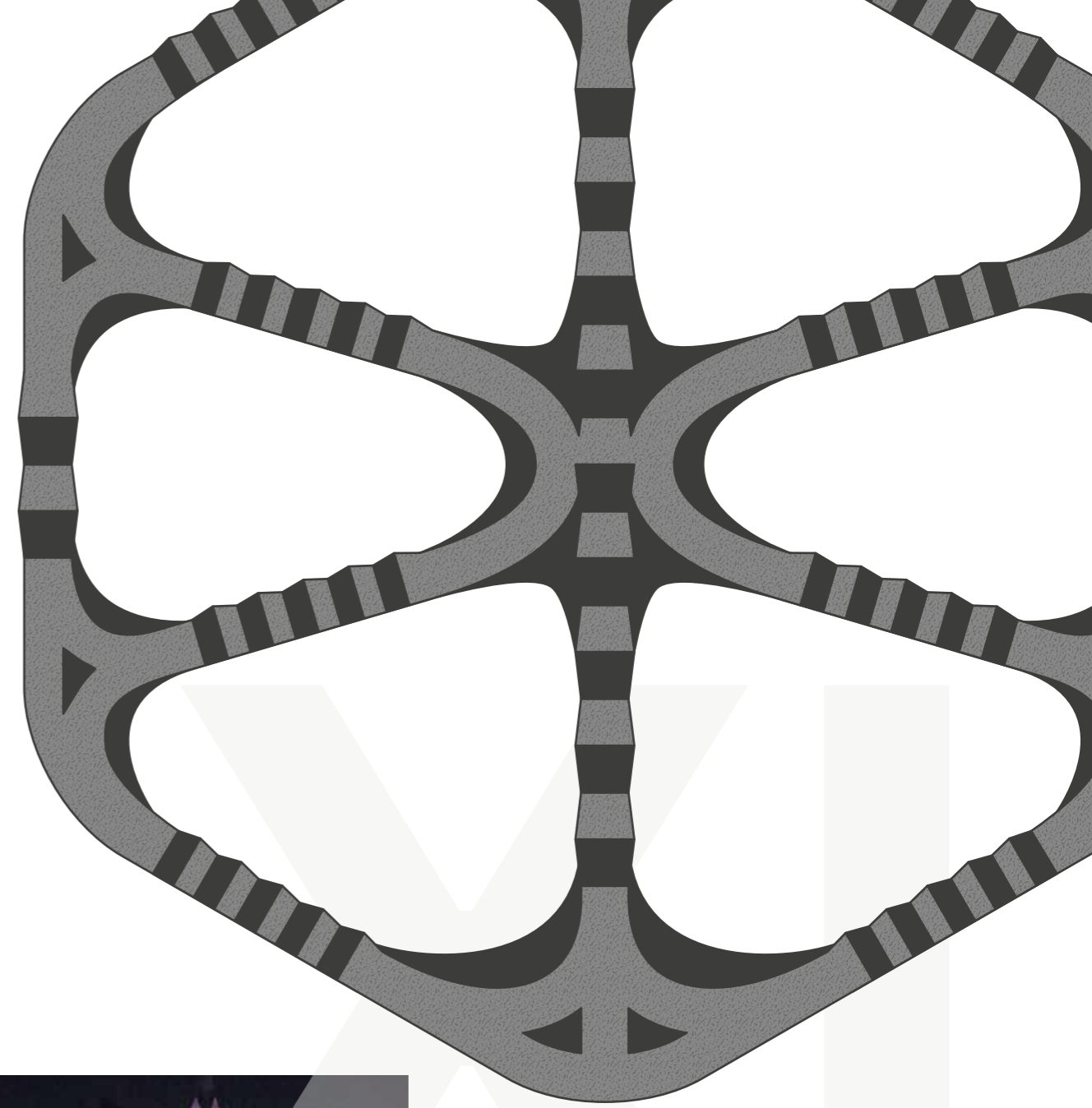
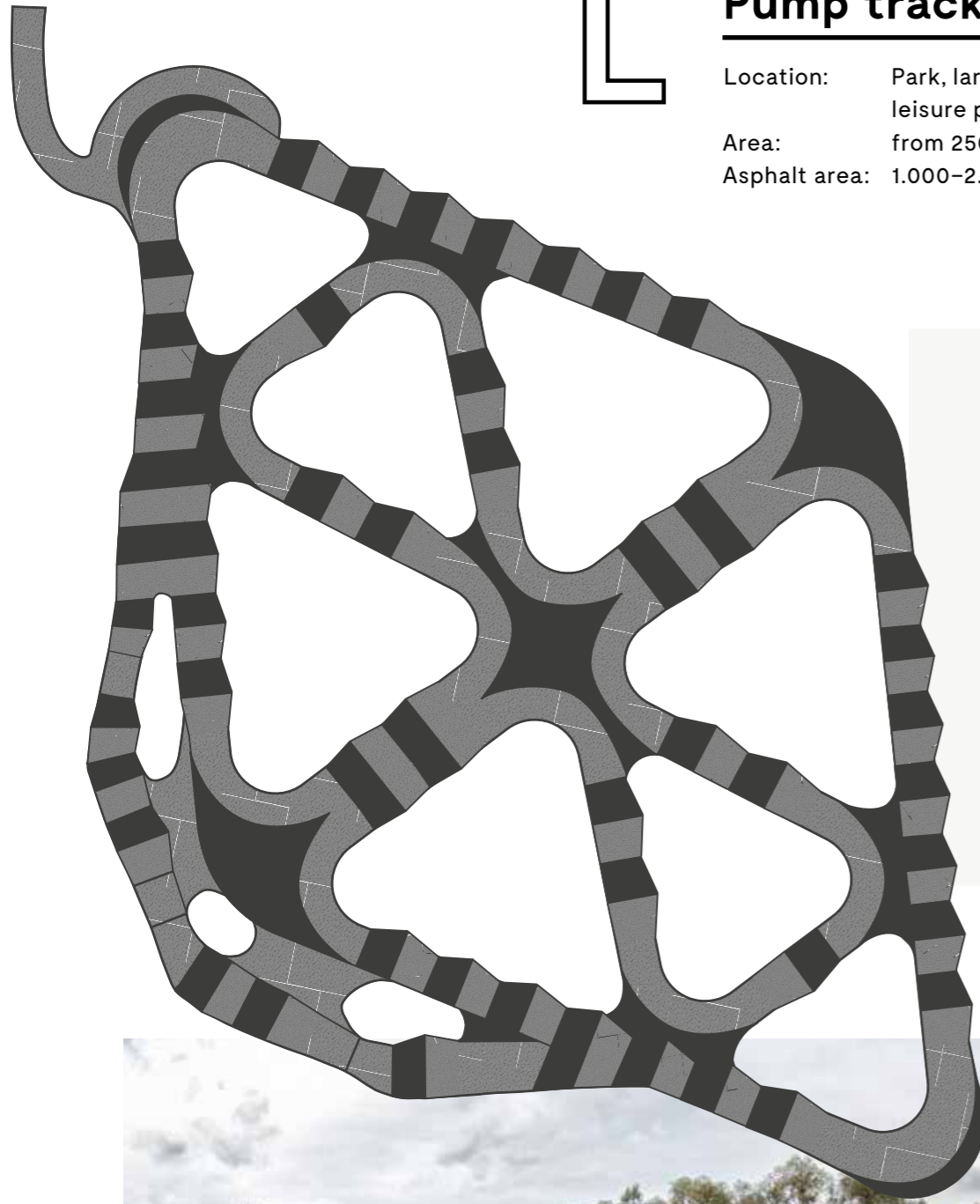

## Urban bike park Pump track

Location: City, leisure park, training facility, hotel  
 Area: from 5000 m<sup>2</sup>  
 Asphalt area: from 2,000 m<sup>2</sup>

# Skills course

In order to introduce beginners to the sport of biking in a skillful and simple way as well as further developing the skills of advanced riders, a practice or skill course is the perfect choice. The practice area, which usually shows hardly any inclination, makes it possible to approach new obstacles and techniques without great danger. Situations such as hairpin bends, drops and root sections, which mountain bikers can also encounter in the "wild", are simulated. This allows you to train specifically for the "outdoor use" in order to improve coordination and balance. Typical obstacles are wooden bridges, balance elements, drops, waves, steep curves and other obstacles made of dirt or stones. The structure of the practice course can range from mobile elements in a flat area to specially groomed trails of varying levels of difficulty.



For the full range of our skills obstacles go to page 104



## Characteristics

### target group

- Mountain bike
- BMX/dirt bike

### current costs

- € low
- € medium
- € extensive

### difficulty level

- very simple
- easy
- medium
- difficult

### surface

- natural finish
- paved
- asphalted
- steel/wood/GRP

### construction measures

- low
- medium
- extensive

### cost per square meter

- | individually |            |             |
|--------------|------------|-------------|
| € 0 - 50     | € 51 - 200 | € 200 - 400 |



## DAV BiKeGarden

Kempton, Germany

Getting ready for the trail, thanks to the training at the DAV BiKeGarden, located directly in the town center- a concept that the German Alpine Association has been practicing similarly with its indoor climbing halls for a long time. The new DAV BiKeGarden in Kempton is now a showcase project to make mountain biking a natural experience.

The facility featuring a wave track, kickers, drops, stone fields, adjoining areas and riding technique sections offers the ideal training environment for teaching technique and safety aspects. The BiKeGarden also offers perfect conditions for the training and further education of guides and instructors. With an area of around 1,450 m<sup>2</sup>, the German Alpine Association is sending a clear signal and pushing the topic with a well-thought-out concept.



## Kids Slopestyle Hoefelmayerpark

Kempton, Germany

Pius (10) & Julius (9) have achieved what many municipalities, initiatives and associations fail to do. They sparked the idea of a Kids Track in their city. The two wrote a letter to Thomas Kiechle the mayor of Kempton who was so excited about the concept that the town now owns a Kids Slopestyle. Kids and teenagers can now find lots of banked turns and jumps on an area of 1,400m<sup>2</sup>. The two boys from the Bavarian region Allgäu demonstrate what it means to show initiative.



## Bike park Klausenmühle

Weitnau, Germany

In 2015, the sports club "TSV Kleinweiler-Hofen" realized that in order to drive and promote mountain biking as a sport in the region and to support young talents, a dedicated training facility was necessary. Together, with the municipality of Weitnau, the sports club approached Schneestern and a small pump track + jump track was realized. The aim was to create an ideal training environment for children and young people.



# Indoor park

Often enough, it can happen that the weather spoils ones plans when it comes to sports. In this case, an indoor park is the ideal opportunity to be active on a bike in any weather and at any time of the year. The Indoor Park is exactly what you make of it: a balance bike track, a pump track, a foam pit or simply all of the above. The possibilities and

combinations are endless and depend mainly on the available space and the needs of the users. With such a facility, fun, exercise and social engagement can be combined under one roof regardless of the weather. In addition, commercial use is an obvious option.



## Characteristics

### target group

- Mountain bike
- Balance bike
- BMX/dirt bike
- Inline kates
- Scooter
- Skate & long board

### difficulty level



### construction measures

- low
- medium
- extensive

### current costs



### surface

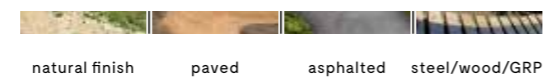

### cost per square meter

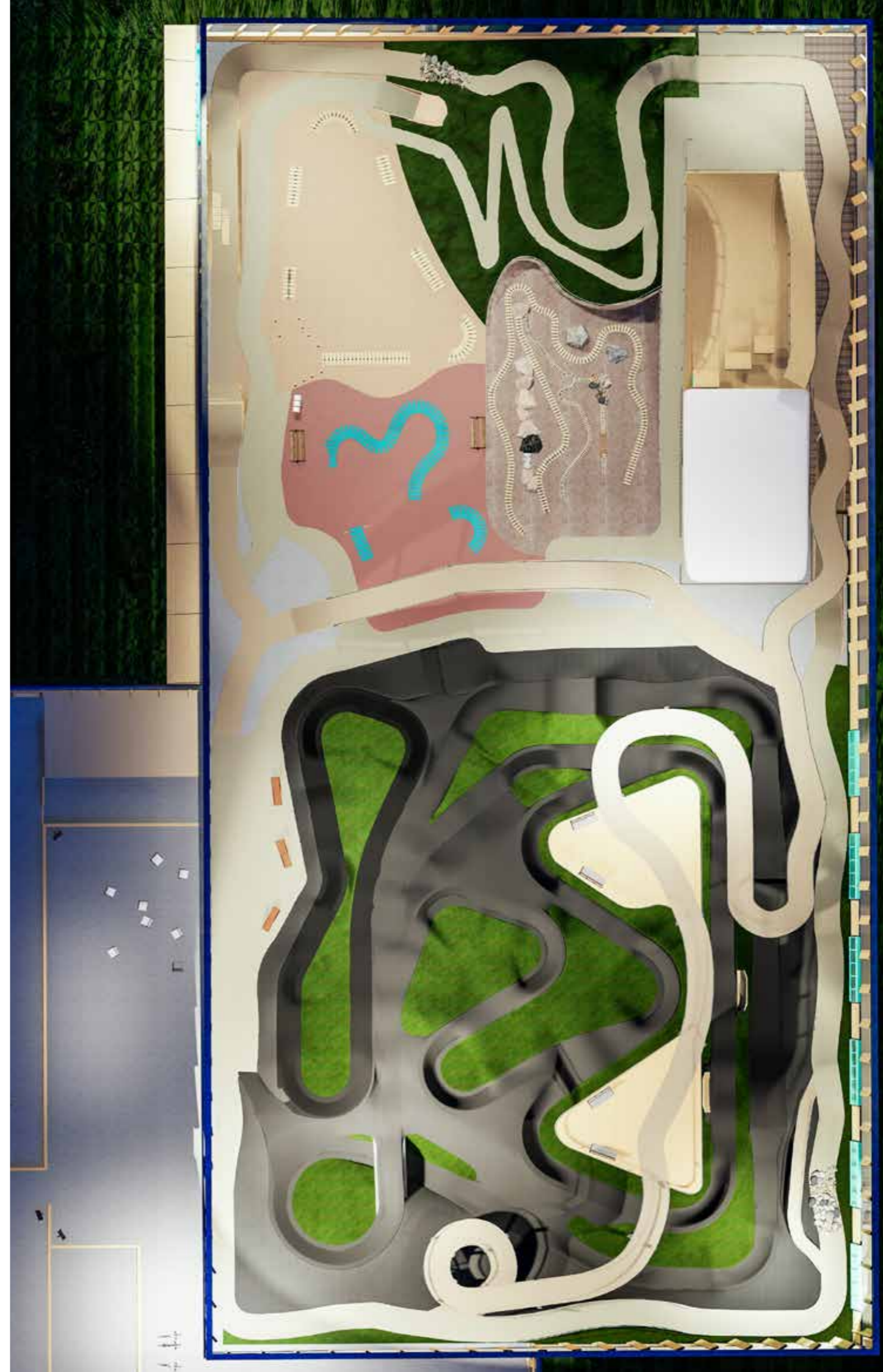
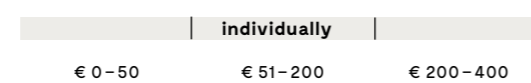

# BMX race track

BMX bikes, who hasn't heard of them?! Small bikes that have become as much a part of urban life as skateboards or scooters. But you often forget that BMXing is also part of the Olympic Games. Up to eight riders compete against each other simultaneously on a race track similar to the principle of the pump track. Such a "race track" can be both mounted and asphalted and leads over waves, jumps and steep-wall bends. With a lot of physical effort and as high a speed as possible, the course

is followed without having to sacrifice the necessary safety, as the driving technique determines the speed. Of course the level of the course can be tailored to the respective target group. In combination with a pump and balance bike track, a BMX racetrack is suitable for general as well as professional promotion of movement and as a training facility for competitive sports.

## Characteristics

### target group

→ BMX

### difficulty level



### construction measures



### current costs



### surface

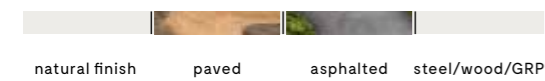

### cost per square meter

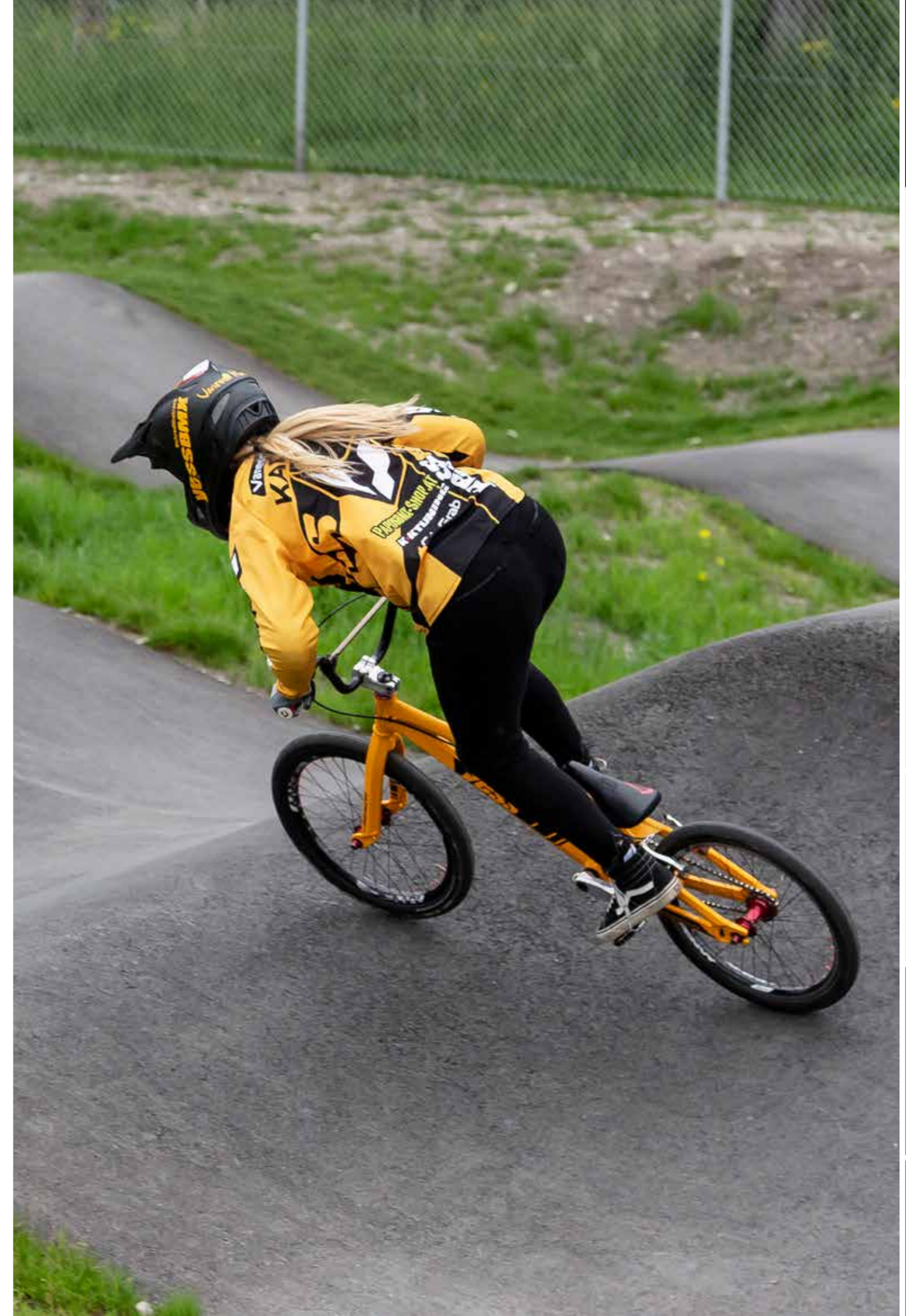
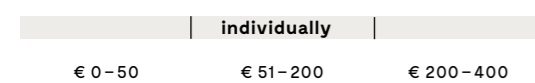

# Dirt park

Even if one hardly suspects it, dirt parks already have a long-standing tradition. With the beginnings of BMXing in America, the desire to create jumps in one's own garden arose. Since then the facilities have changed due to the influence of MTB sports, but the principle has remained the same: On a mostly flat level, one can find specially groomed and possibly paved tracks featuring typical obstacles such as jumps, berms and waves for each

level of ability. The dirt park is characterized by its perfectly coordinated sequence of jumps with variable levels of difficulty. While beginners can still roll over the jumps, more difficult lines have to be completely cleared in order to land safely. The slopestyle course can be seen as an extension of the dirt park, where the use of e.g. wooden obstacles and artificial ramps plays a central role.



## Characteristics

### target group

- Dirtbike
- BMX
- Mountain bike

### difficulty level



### construction measures

- low
- medium
- extensive

### current costs

- low
- medium
- extensive

### surface



### cost per square meter





**BIKE**  
EQUIPMENT

# Safety first!

Besides our winter division Snow, action sports in Summer are the largest product segment here at Schneestern. In order to sustainably establish bike trails and facilities as well as the right equipment in summer sports, it was crucial for us to always consider safety to be the most important aspect of all. However, anyone can talk about safety in action sports. But we can prove it.



In addition to the Schneestern quality management, we—as the only company for Action Sport Parks & Equipment worldwide—have been subjecting our products as well as our production site to an independent quality and safety test by the TÜV Süd since 2008.

However, before the Schneestern quality seal and the TÜV Süd sticker are applied, all our products must undergo a specially developed program consisting of 16 production steps and three quality controls. Leaving you confident that all our products meet the high safety requirements that you expect in regard to the responsibility towards your guests. Only safe products allow a broad acceptance and a further development of action sports.

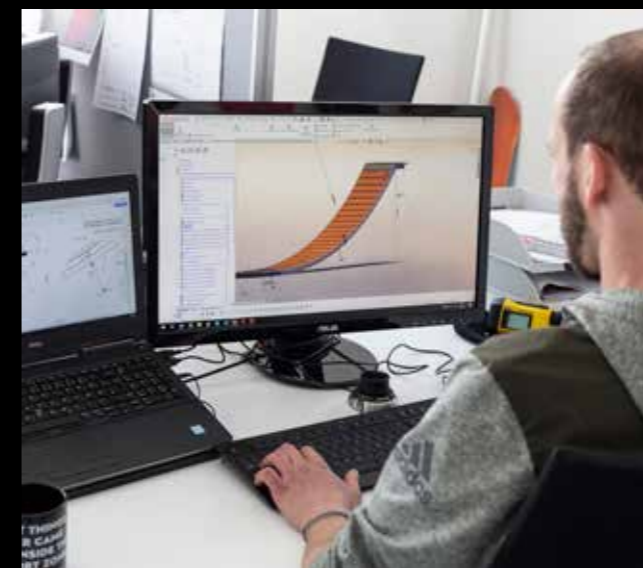
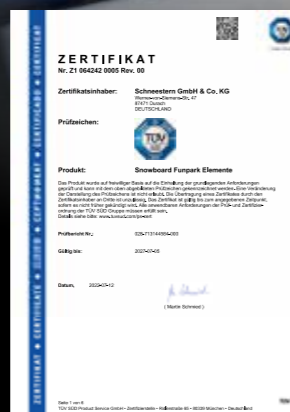

## Made in Germany

We have chosen Germany as our production location! In our 5000 m2 production facility, located in the southern part of the Allgäu, we produce action sports equipment to the highest quality standard. Thereby, we trust in a reliable and predominantly regional supplier network.

## Developed in Germany

A simple “wooden ramp” can hardly be described as professional bike equipment. Like traditional industrial sectors, we also focus on standardized and sustainable product development. This is ensured by our in-house design office, which carefully plans all products with SolidWorks, leaving nothing to chance.

## Made to last— Product tests

Our customers are the ones who know best. Outdoor products are often exposed to extreme conditions such as through nature or high wear and tear by guests. For this reason and because safety is our top priority, we leave nothing to chance. We test our products to their limit before they go on sale. Our dedicated testing environment and team implement this process.



# Technical Customer Service

360-degree concepts play an important role in our company philosophy. A holistic support of our customers is of great importance to us. Therefore, we have created the world's first customer service in the action sports industry for our products. As the final component of our 360-degree service, we offer our technical customer service. A 24hr hot-line and an on-site service guarantee consistent quality, even as the use and complexity of our products increases.



## OUR SERVICES:

- On-site service
- Technical support in case of problems
- Assembly support for technical products
- Carrying out repairs
- Replacement and maintenance work on your Schneestern products
- Inventory after the season and documentation of damages
- Europe-wide
- Cost upon request or via possible service flatrate



**SERVICEHOTLINE: +49 831 960 886 56**

# Delivery

Whether a mountain cableway in the Alps or the delivery to a municipality in Northern Germany, our customers themselves have made us logistical experts in our 20-year company history. For this reason, we offer worldwide delivery for all our products. Do you want our bike equipment in your destination? Together with our selected logistics network, we deliver it straight to the trail.

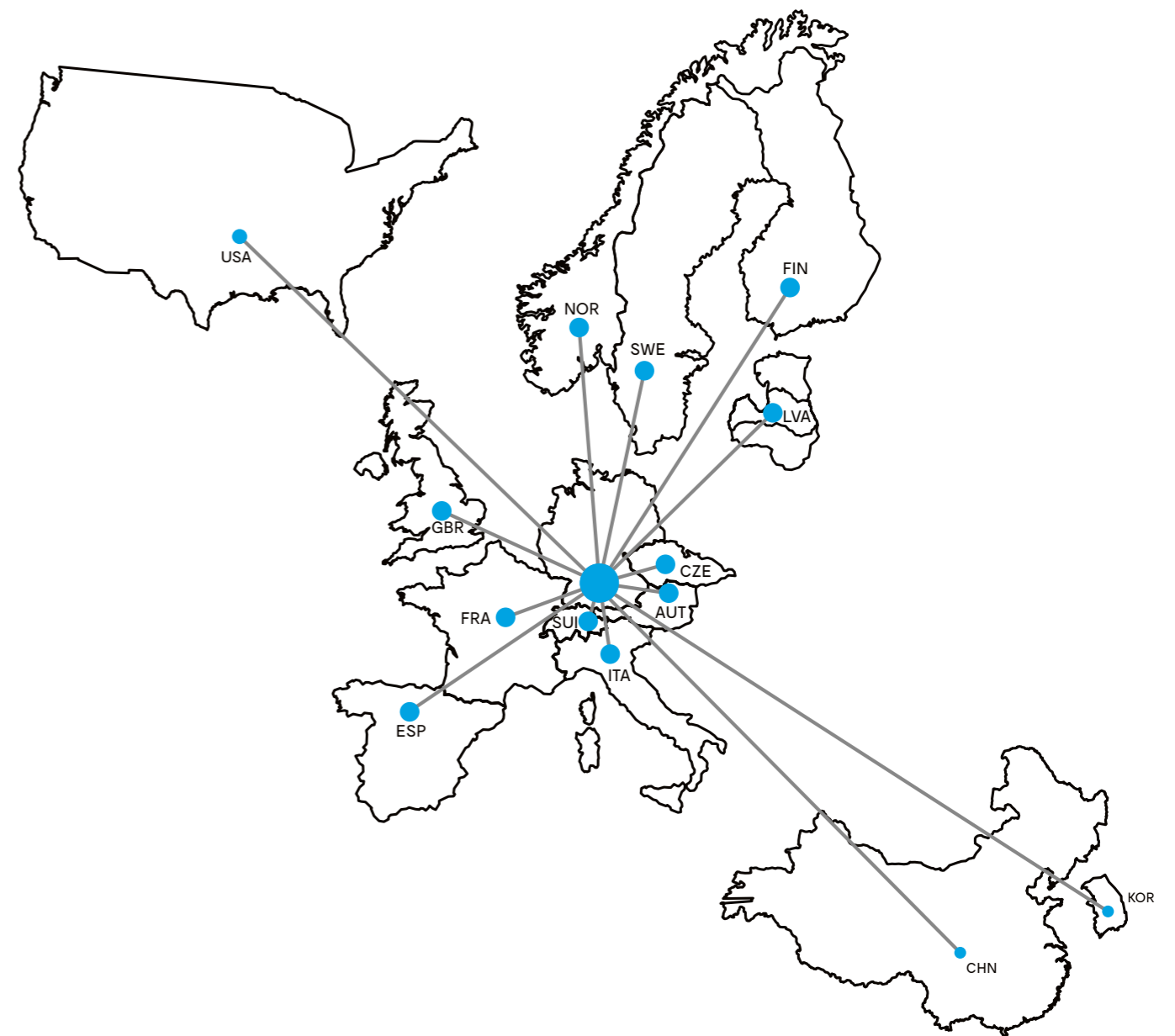



SKILLS  
OBSTACLES

# Skills Obstacles



Besides their mobility and manageable costs, a great advantage of training elements is their individuality. No matter the target group or purpose, there are hardly any limits to the shape and design of the constructions. This is exactly what makes them perfect for use in bike schools and practice courses. Situations from the world of biking can be simulated and practiced practically without danger. These elements are also ideal for improving skills and techniques. In this area Schneestern draws on the know-how and experience of "TrailXperience". A provider of high-quality biking tours and technical riding courses who, as our cooperation partner, knows how important professional practice elements are. Mobile elements are particularly interesting due to the fact that they can not only be combined with one another at any time, but can also be set up or dismantled as desired.

rience of "TrailXperience". A provider of high-quality biking tours and technical riding courses who, as our cooperation partner, knows how important professional practice elements are. Mobile elements are particularly interesting due to the fact that they can not only be combined with one another at any time, but can also be set up or dismantled as desired.

## Advantages

- Quality products "Made in Germany"
- TÜV Süd-certified
- Outdoor and indoor use
- Permanent and temporary use
- Different levels of difficulty
- Individually combinable elements
- Tailored to riding technique trainings
- Suitable for children due to its low drop height
- Individualized elements upon request

## Characteristics

### target group

- Tour; Marathon/Cross-Country
- All Mountain/Enduro
- Freeride/Downhill
- Target group zero

### difficulty level



### construction measures



### current costs



### surface



### cost per square meter

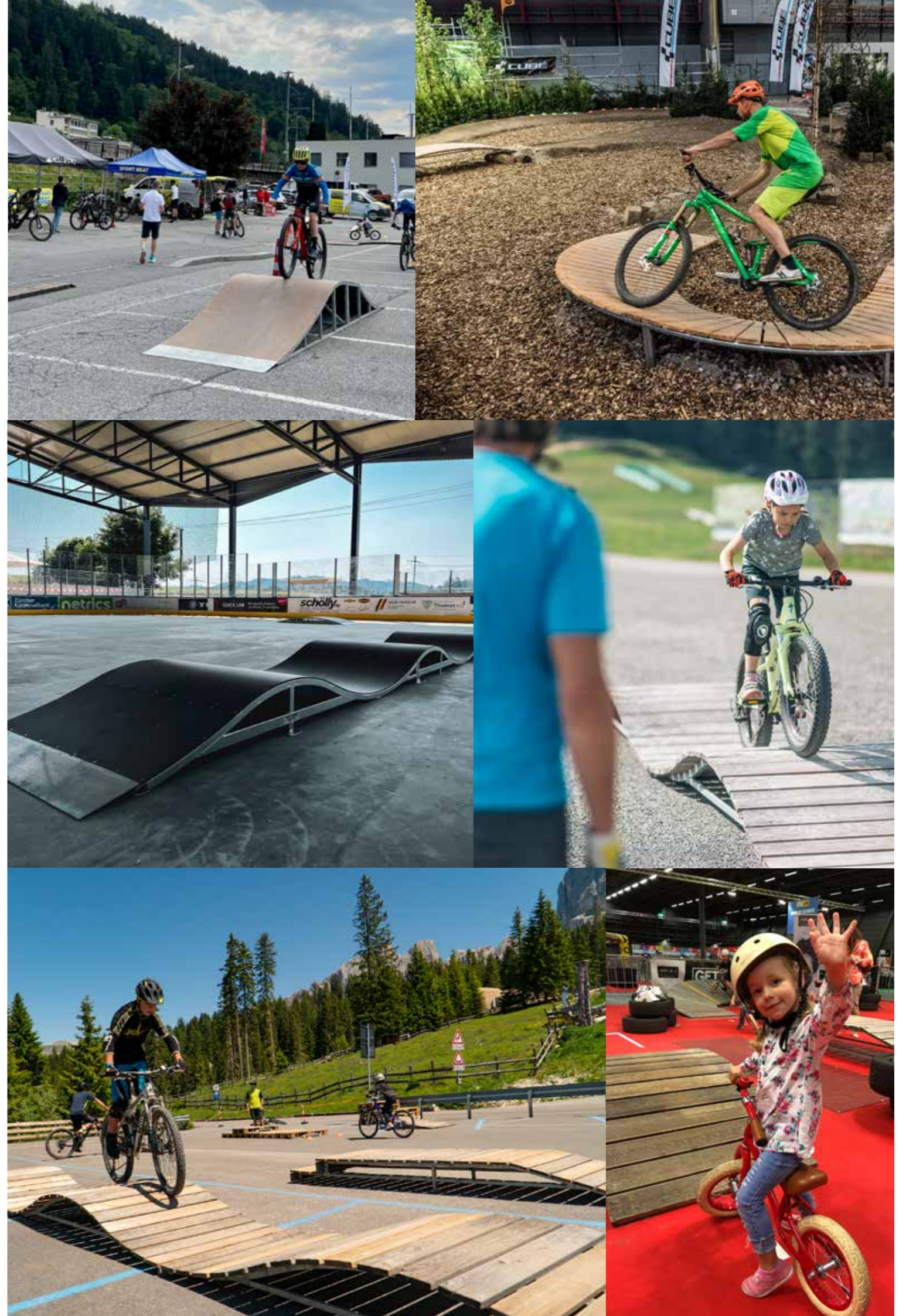

EQUIPMENT

Safety

Customer Service

Delivery

Skills Obstacles

Artificial Obstacles

Add-ons

Modular Pump track

# Sample courses

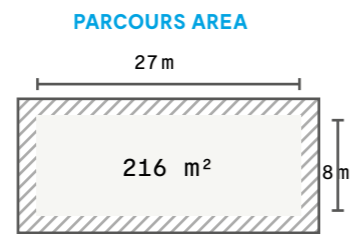
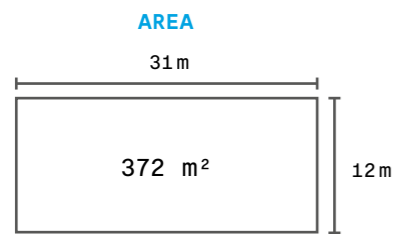
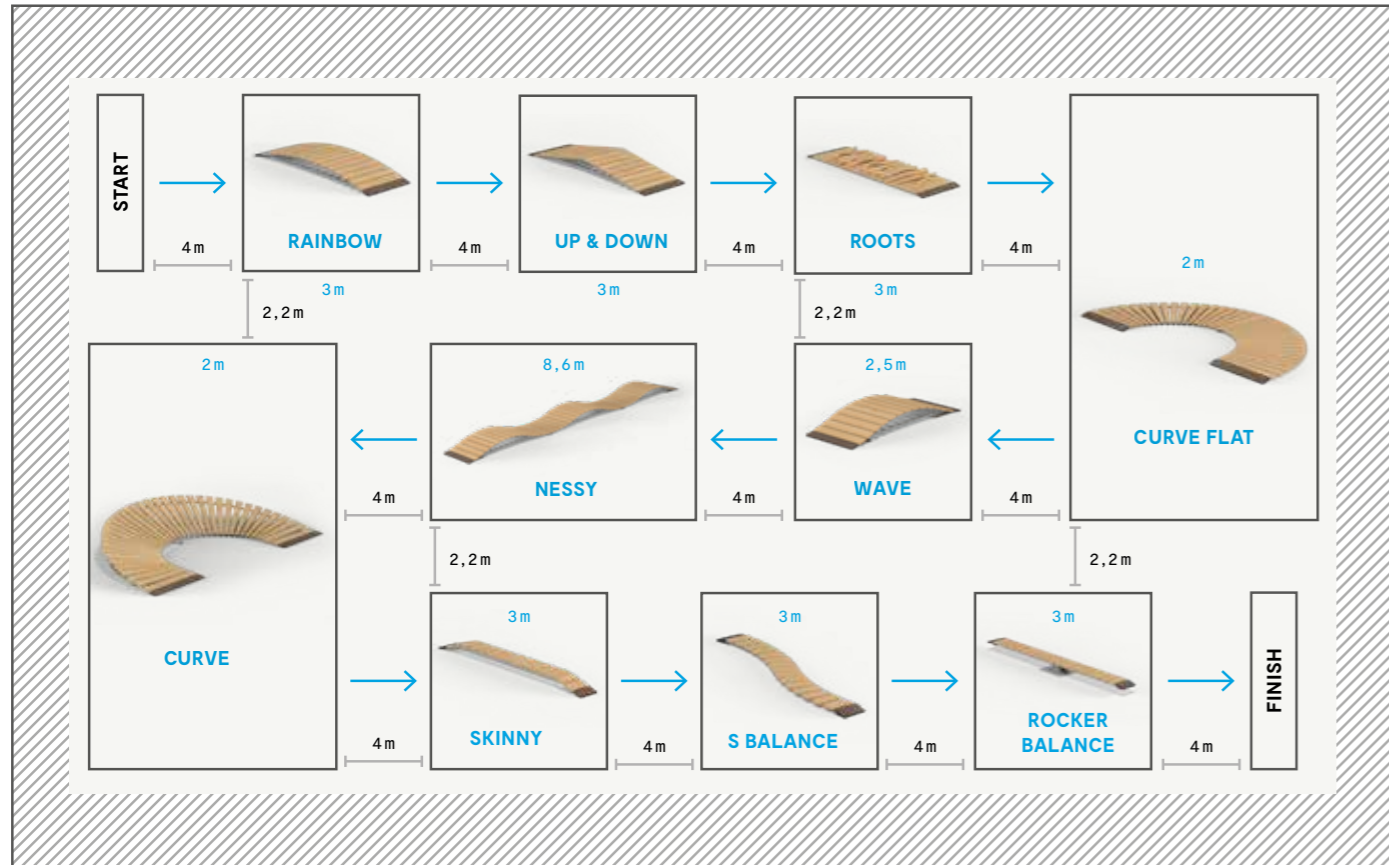

2 m safety distance according to DIN EN 14974



## CLASSICS

For all products:  
paneled with 27mm larch wood; incl. floor anchoring set (4x pegs, 4x multimonti)  
Entry and landing boards as well as drop steps made of colored and weather-resistant WPC plastic



### RAINBOW

Order no. 3576



Dimensions: 3m long, 0.95m wide, 0.3m high; approx. 70kg weight

One-piece galvanized steel construction

### WAVE

Order no. 3580



Dimension: 2,5m long, 0,95m wide, 0,32m high; approx. 60kg weight

One-piece galvanized steel construction

### STEP-UP WAVE

Order no. 3578



Dimensions: 3.8m long, 0.95m wide, 0.33m high; approx. 90kg weight

One-piece galvanized steel construction

### NESSY

Order no. 3577

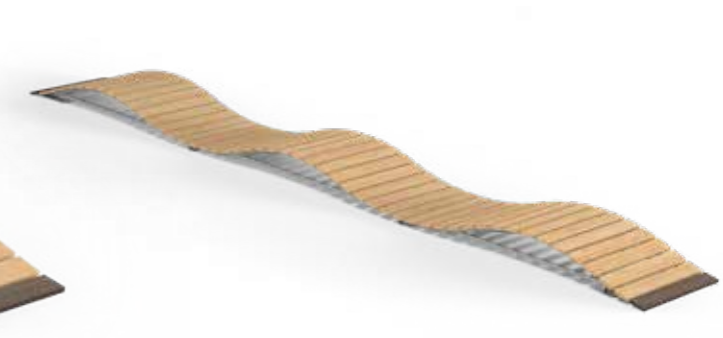

Dimensions: 8.6m long, 0.95m wide, 0.3m high; approx. 200kg weight

Three-part galvanized steel construction

## LAUNCH

Order no.3788



Dimensions: 1.5m long, 0.95m wide, 0.23m high; approx. 35kg weight

One-piece galvanized steel construction

## UP & DOWN

Order no.4750



Dimensions: 3m long, 0.95m wide, 0.3m high; approx. 70kg weight

One-piece galvanized steel construction



## KICKER

Order no.3579



Dimensions: 4m long, 0.95m wide, 0.35m high; approx. 95kg weight

One-piece galvanized steel construction



## STEP

Order no.3165



Dimensions: 3.5m long, 0.95m wide, 0.3m high; approx. 85kg weight

One-piece galvanized steel construction

## ROOTS

Order no.4221



Dimensions: 3m long, 0.95m wide, 0.1m high; approx. 80kg weight

One-piece galvanized steel construction planked with different types of Robinia trunks

## STEP UP & STEP DOWN

Order no.4749

Dimensions: 7.5m long, 0.95m wide, 0.3m high; approx. 195kg weight

One-piece galvanized steel construction



## CURVES

**For all products:**  
planked with 27mm larch; incl. floor anchoring set (4x pegs, 4x multimonti) Entry and landing boards as well as drop steps made of colored and weather-resistant WPC plastic



### CURVE FLAT

Order no. 3629



Dimensions: 4.2m long, 1.1m wide, 0.1m high; approx. 115kg weight

Two-piece galvanized steel construction

### CURVE

Order no. 3630



Dimensions: 4.2m long, 1.1m wide, 0.55m high; approx. 150 kg weight

Two-piece galvanized steel construction

## BALANCE

**For all products:**  
Planked with 27mm larch; incl. floor anchoring set (4x pegs, 4x multimonti)  
Entry and landing boards as well as drop steps made of colored and weather-resistant WPC plastic

### STRAIGHT BALANCE

Order no. 3581



Dimensions: 3m long, 0.3m wide, 0.1m high; approx. 30kg weight

One-piece galvanized steel construction

### S BALANCE

Order no. 3585



Dimensions: 3m long, 0,3m wide, 0,1m high; approx. 30kg weight

One-piece galvanized steel construction

## RAINBOW BALANCE

Order no.3583



Dimensions: 3m long, 0.3m wide, 0.3m high; approx. 35 kg weight

One-piece galvanized steel construction

## SKINNY BALANCE

Order no.3582



Dimensions: 3m long, 0.3m wide, 0.17m high; approx. 40kg weight

One-piece galvanized steel construction

## STEP UP & DOWN BALANCE

Order no.4748



Dimensions: 7.5m long, 0.3m wide, 0.3m high; approx. 110kg weight

Three-part galvanized steel construction

## UP & DOWN BALANCE

Order no.3584



Dimensions: 3m long, 0.3m wide, 0.3m high; approx. 35kg weight

One-piece galvanized steel construction

## ROCKER BALANCE

Order no.3586



Dimensions: 3m long, 0.3m wide, 0.2m high; approx. 85kg weight

One-piece galvanized steel construction with rocking joint



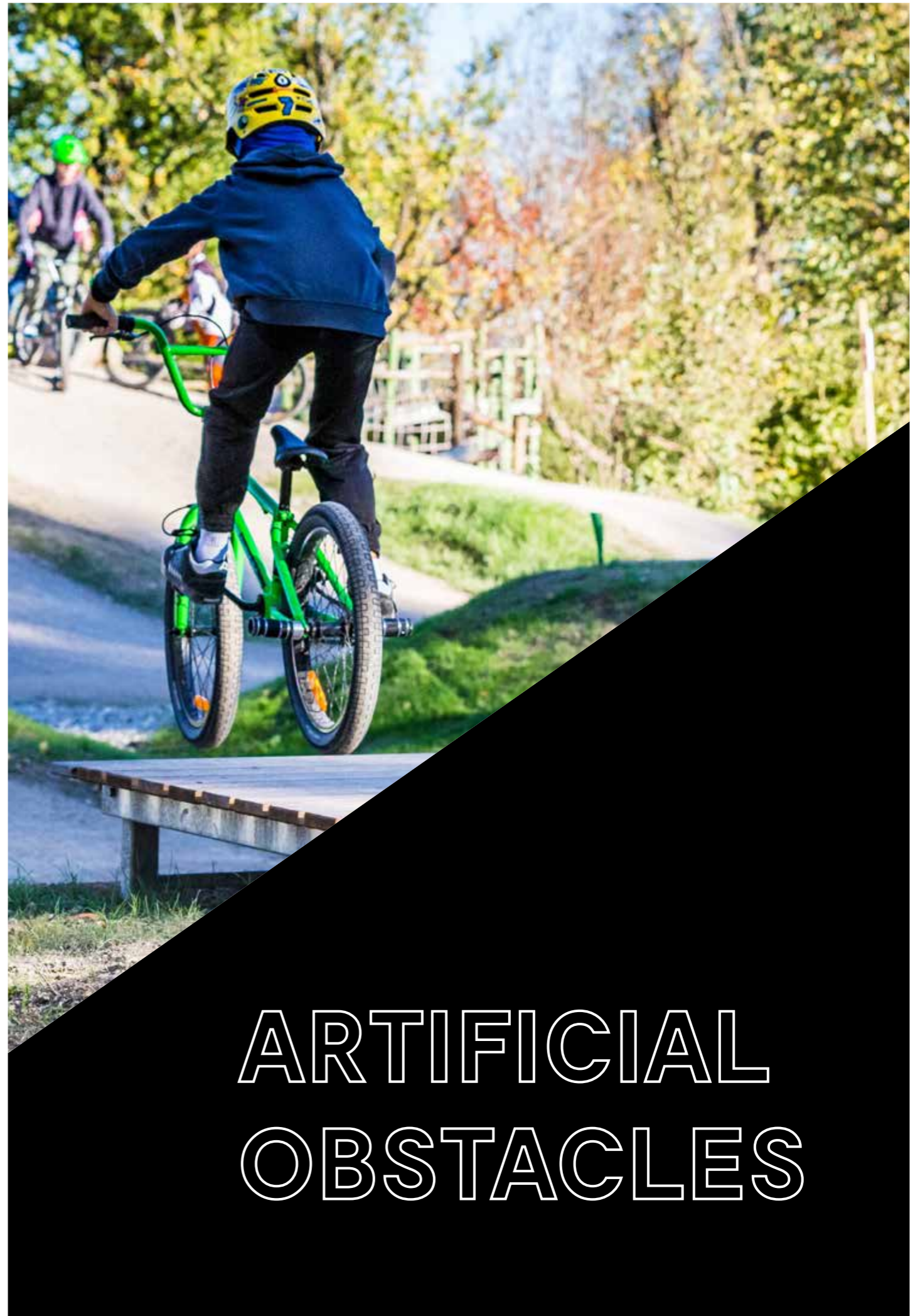

ARTIFICIAL  
OBSTACLES



# Artificial obstacles

Natural obstacles are often not enough for some facilities and trails in question. Consequently, artificial sections must be added. With our artificial obstacles, we have created a standardized and TÜV Süd-certified product range that makes it easy to assemble diverse technical riding obstacles. The spectrum ranges from simple drops to complex wooden constructions. Any artificial elements are possible.

## Target groups

- All Mountain / Enduro
- Freeride / Downhill

## WALLRIDE FOR BANKED TURNS MEDIUM

Order no.7660



Dimensions: 10m long, 1,1m high

Four-part hot-dip galvanized steel construction  
Lateral larch planking, Larch planking, larch painted with special paint  
Opening angle Total/overall curve 180°  
incl. floor anchoring

- Anti-slip surface
- Standardization
- Riding safety through consistent quality & type of obstacles
- Reduced maintenance & servicing
- Anchoring options
- TÜV Süd-certified

## WALLRIDE FOR BANKED TURNS SMALL

Order no.7737



Dimensions: 4,5m long, 1m high

Three-part hot-dip galvanized steel construction  
Lateral larch planking, Larch planking, larch painted with special paint  
Opening angle Total 53°  
incl. floor anchoring

## DROP LARGE

Order no.5580

Dimensions: 4 m long, 0,95 m wide, 0,9 m high

Hot-dip galvanized steel construction planked with larch, entry and landing boards made of color-contrasting WPC plastic, incl. floor anchorage

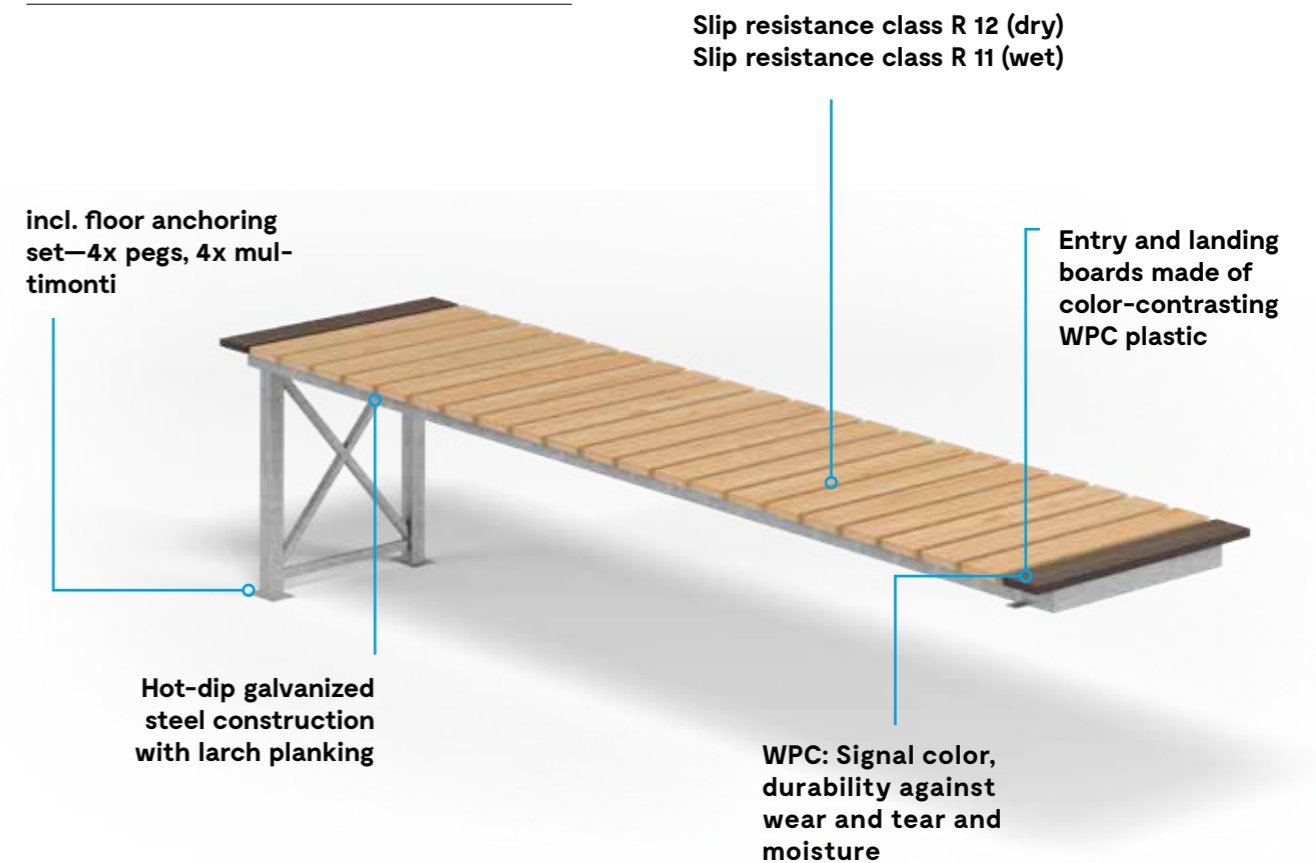

## DROP MEDIUM

Order no.5579



Dimensions: 4 m long, 0,95 m wide, 0,6 m high

## DROP SMALL

Order no.5085



Dimensions: 4 m long, 0,95 m wide, 0,3 m high



## JUMP LARGE

Order no.7836

Dimensions: 4,20 x 0,95 x 1,8m (l x w x h)  
Take off angle 52°

Hot-dip galvanized steel construction planked with larch, access and take-off boards made of color-contrasting WPC plastic, incl. floor anchorage

Slip resistance class R 12 (dry) Slip resistance class R 11 (wet)



HOT-DIP GALVANIZED STEEL CONSTRUCTION WITH LARCH PLANKING

WPC: Signal color, durability against wear and tear and moisture

Access and take-off boards made of color-contrasting WPC plastic

incl. floor anchoring set—4x pegs, 4x multimonti

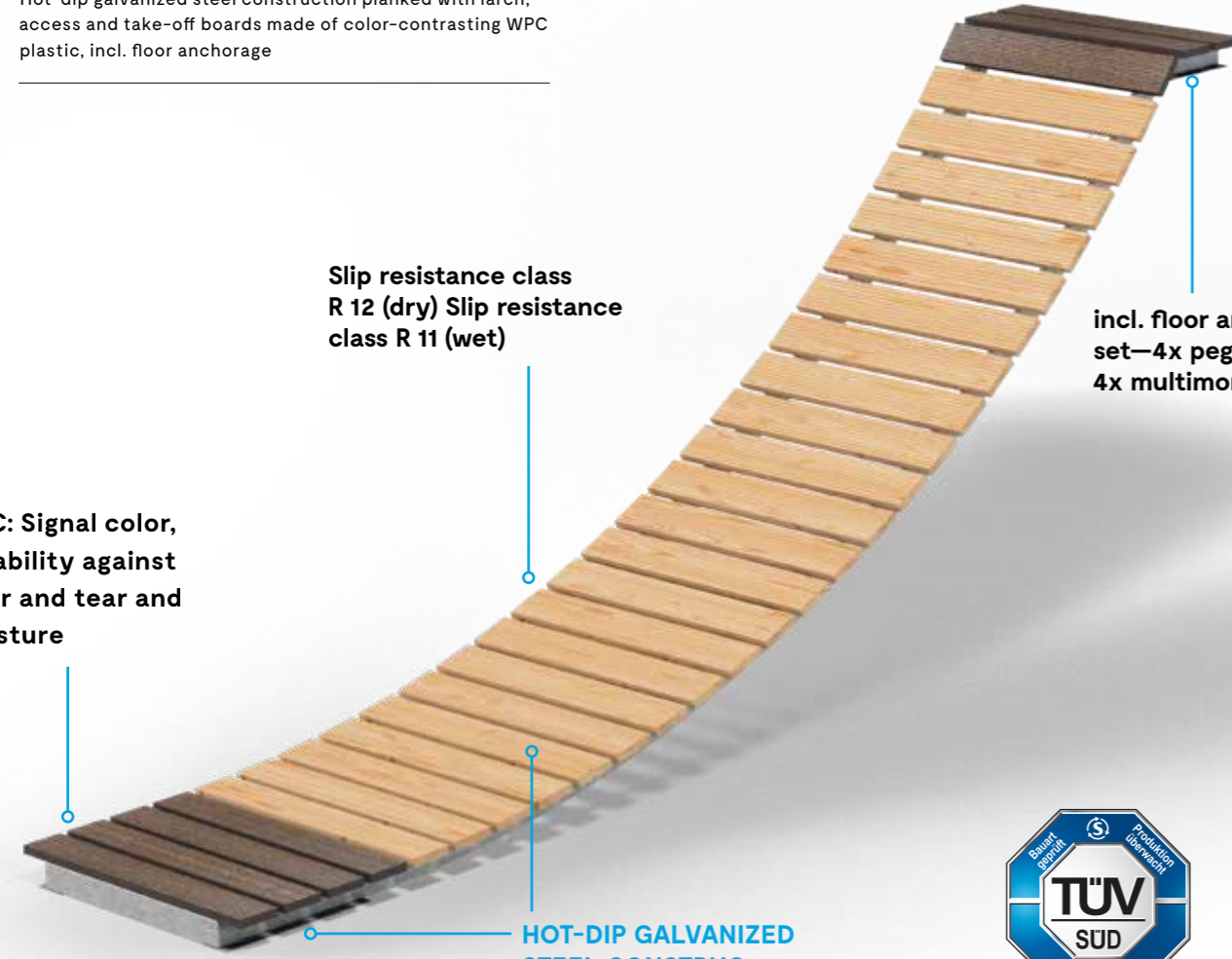

## JUMP MEDIUM

Order no.7835



Dimensions: 4,2 m long, 0,95 m wide, 1,4 m high  
Take off angle: 46°

## JUMP SMALL

Order no.5624



Dimensions: 4,2 m long, 0,95 m wide, 1,1 m high  
Take off angle: 39°



EQUIPMENT

Safety

Customer Service

Delivery

Skills Obstacles

Artificial Obstacles

Add-ons

Modular Pump track



# Safety concepts:

## Our add-ons in action

Helmets and protective equipment are an indispensable part of today's bike sport. However, the aspect of safety goes much further. Of course, the responsibility is not only limited to the athletes themselves but extends to the associated sports complexes.

Safety and risk management must be given high priority in the planning and construction of a bike facility. The aim is not only to reduce the accident rate, but to ensure the greatest possible riding experience. When planning the design of trails and facilities, multiple aspects must be coordinated in order to create a thoroughly coherent picture. Trail, safety and signage concepts must intertwine in order to achieve the full potential of a bike facility.

Such an implementation is exemplified by the bike park, Bikewelt Schöneck. There, the aspect of safety goes far beyond mere signage and the marking or securing of hazardous areas. Thus, the entire area was divided into multiple sections of rescue. As a result, a rescue guide for the police and emergency services was developed. The entire signage and protection processes of the bike facility is based on this well-thought-out principle. These aspects work coherently to function as maximum safety precautions for visitors and range from simple drops to complex wooden constructions. Any artificial elements are possible.



# ENTRANCE SOLUTIONS

## TRAIL HEAD

Order no. 7956

Dimensions: 2,5m high

Dibond covered  
fully covered with laminated digital print  
incl. open/closed board  
incl. anchor and mounting for concrete foundation



## ENTRANCE BOARD

Order no. 5108

Dimensions: 3,5m high, 4m wide

Douglasienbohle 4m wide/ 1,4m high an Robinienstämmen  
inkl. Fräsung  
inkl. Anker und Aufnahme für Betonfundament



# SIGNS

## For all products:

The following applies to all products: sign is mounted on weather-resistant, non-splintering Robinia wooden pole, rounded PVC sign is covered with digital print.

## HAZARD BOARD

Order no. 7697 both sides / 3186 one side



0,3m x 0,3m

## DIRECTION SIGN

Order no. 7698 both sides / 3184 one side



0,3m x 0,15m

## FORBIDDEN SIGN

Order no. 3185



0,3m x 0,3m

## INFORMATION SIGN

Order no. 7699 both sides / 4093 one side



0,2m x 0,2m



S

M



L

# OVERVIEW BOARD

S

Dimensions: 2,56m high, 0,87m wide

- Information board with usage rules
- incl. hot-dip galvanized steel frame
- incl. board made of 4mm aluminum composite material (graphic area 0.75 x 1m)
- incl. scratch-resistant and laminated digital print
- excl. concrete foundation and installation
- excl. graphic design (customizable)
- excl. delivery (depending on delivery address)

M

Dimensions: 2,56m high, 1,62m wide

- Information board with usage rules
- incl. hot-dip galvanized steel frame
- incl. board made of 4mm aluminum composite material (graphic area 1,5 x 1m)
- incl. scratch-resistant and laminated digital print
- excl. concrete foundation and installation
- excl. graphic design (customizable)
- excl. delivery (depending on delivery address)

L

Dimensions: 2,94m high, 3,17m wide

- Information board with usage rules
- incl. hot-dip galvanized steel frame
- incl. board made of 4mm aluminum composite material (graphic area 3 x 1,5m)
- incl. scratch-resistant and laminated digital print
- excl. concrete foundation and installation
- excl. graphic design (customizable)
- excl. delivery (depending on delivery address)



S

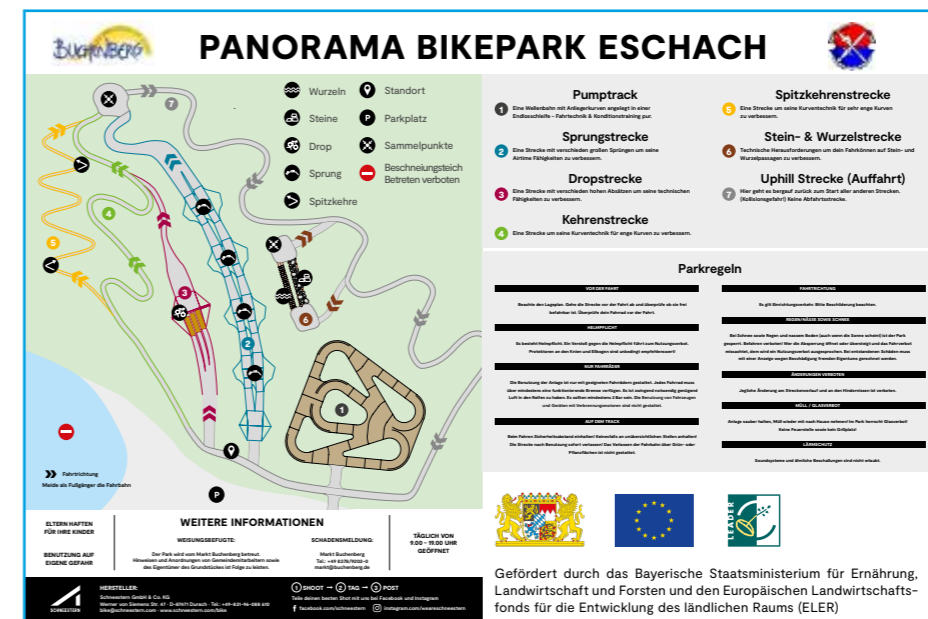

M

EQUIPMENT

Safety

Customer Service

Delivery

Skills obstacles

Artificial obstacles

Add-ons

Modular pump track

# BUILDER'S SHAPE TOOL

It took around three years of development time with numerous meetings, prototypes and tests until we were able to launch the first professional "Made in Germany" shape tool for trail, path, garden and landscaping on the market.

Our tool is suitable for tamping, raking, hacking, leveling, loosening and combines five work steps in one tool. A blade made of high-strength special steel, as well as re-sharpenable blades and teeth, make the Builder's Shape Tool a long-term companion, for all individuals who are involved in the construction of trails. This was already proven at the pilot seminar "Risk Management & Road Construction" of the German Alpine Club last year, where our tool was tested thoroughly.

## Product advantage

- Blade made of high-strength special steel (powder-coated)
- Only 1 tool for 5 work steps
- Re-sharpenable blades and teeth
- Extra-long, replaceable pole
- Ergonomically balanced
- Optimum working angle
- Low weight

## Fields of application

- Trails, paths, dirt parks, pump tracks
- New construction and maintenance (Reshape)

## BUILDERS SHAPE TOOL

Order no.3841

Dimensions: wideness spade: 9 cm, length handle: 150 cm, weight: 2,5 kg

Multifunctional shaping tool made of high-strength and powder-coated special steel incl. exchangeable wooden pole.



Marc Torsius · Director IMBA Europe

"A must-have for every trail builder"

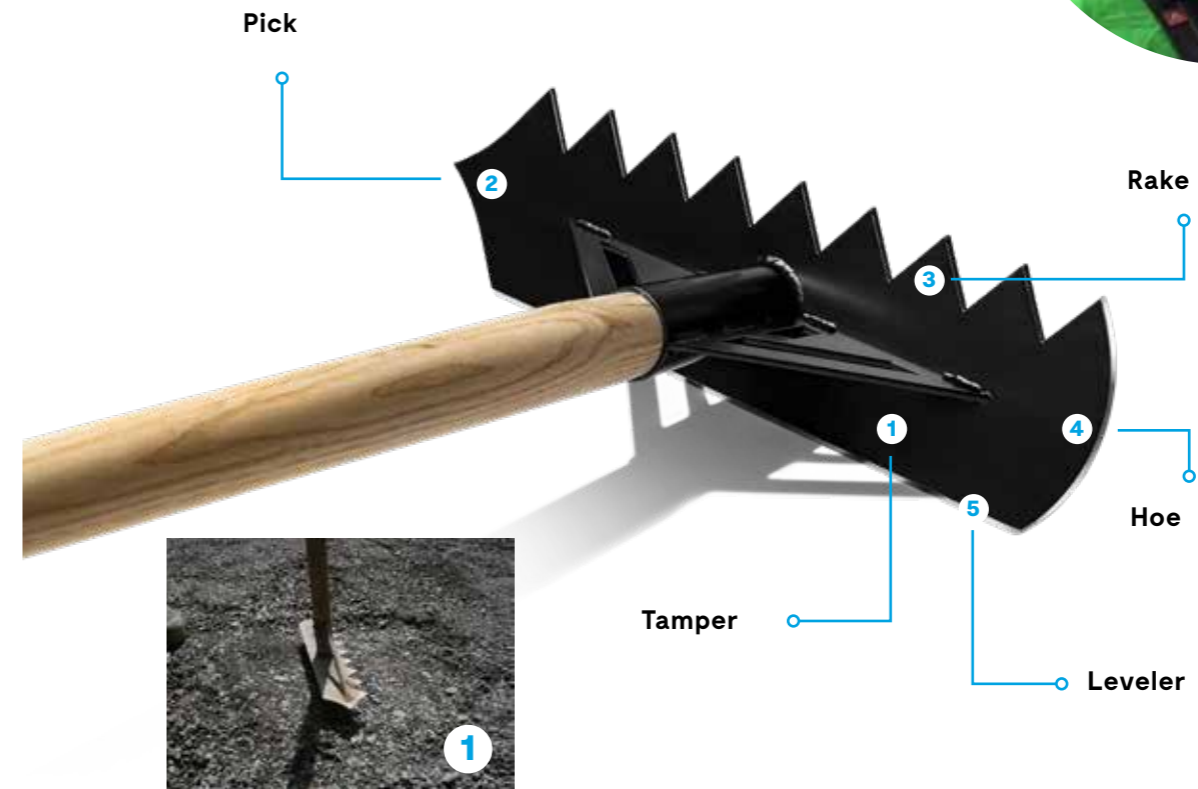



### IMPACT SAFETY PROTECTION MAT SMALL

Order no.4078

Dimensions: 2m x 2m x 0,08m

incl. straps for tying  
Color: RAL6005 Moss green

### IMPACT SAFETY PROTECTION MAT U-PROFILE SMALL

Order no.4080

Dimensions: 2m high, 0,2m inside, 0,36m outside

incl. straps for tying  
Color: RAL6005 Moss green

### IMPACT SAFETY PROTECTION MAT LARGE

Order no.4079

Dimensions: 3m x 2m x 0,08m

incl. straps for tying  
Color: RAL6005 Moss green

### IMPACT SAFETY PROTECTION MAT U-PROFILE LARGE

Order no.4081

Dimensions: 2m high, 0,4m inside, 0,56m outside

incl. straps for tying  
Color: RAL6005 Moss green

### JUMP MARK GREEN OR RED

Order no.7720

Jump marks green or red

### PRE DRILLING FOR JUMP MARKS

Order no.7829

Galvanized steel





# BIKE

## References



**SINCE 2014 MORE  
THAN 30 PROJECTS  
AND 170 OBSTACLES  
IN GERMANY  
AND AUSTRIA**

### GERMANY

- Biberach: Pump track
- Füssen: Pump track
- Leipzig: Pump track
- Pegnitz: Pump track
- Aachen: Pump track
- Groß-Umstadt: Balance bike track / pump track
- Schöneck: Bike park
- Weitnau: Pump track / jump track
- Burladingen: Flow trail
- Oberammergau: Flow trail / jump trail
- Kusterdingen: Bosch eTrail Parcours
- Eschach: Skillcenter Allgäu
- Kempten: DAV skills parcours / kids slopestyle
- Herrieden: XC bike park
- Erfurt: Trade show Sport Aktiv
- Munich: eBike days / Bike & Style
- Germering: Pump track
- Weiterstadt: BMX race track
- Datteln: Pump track
- Eberswalde: Pump track
- Pfronten: Pump track
- Perl: Pump track / balance bike track / skills parcours / trail / XC trail
- Salem: „Urban Sports Park“ with pump track / dirt line & skate park
- Gerolzhofen: „Urban Sports Park“ with kids pump track & concrete skate ramp
- Straubing: Pump track
- Kaarst: Pump track
- Kernen: Pump track & skate bowl
- Staig: Pump track
- Monschau / Kalterherberg: Bike park / technique / skills / pump track
- Oberhof: Bike park / trails / pump track / air bag
- Rabenberg: Bike playground
- Betzigau: Pump track

### AUSTRIA

- Neunkirchen: Pump track
- Annaberg: Mini bike park / modular pump track
- Saalbach: Skills Area Lengauer Hof
- Alpbach: Pump track
- Knittelfeld: Pump track
- Ligist: Pump track
- Leogang\*: Pump track / Jump track
- Lermoos: Pump track
- Wals-Siezenheim: Pump track / Jump track
- Mittersill: Balance bike track / pump track / Jump track / Skills track
- Linz: Pump track
- Pischelsdorf am Engelbach: Pump track
- Wien: Bike motor park
- Gunskirchen: Pump track

### WELTWEIT

- Guiyang (China): Pump track center

# Network of partners

We rely on a strong network to utilize synergies and to collectively push the bike sport forward. Therefore, we are proud members and networkers of the following partners.

## MEMBERS OF:

IAKS: Internationale Vereinigung Sport- und Freizeiteinrichtungen



DIMB: Deutsche Initiative Mountainbike



FLL: Forschungsgesellschaft Landschaftsentwicklung Landschaftsbau e. V.



VDS: Verein Deutscher Seilbahnen



HWK: Handwerkskammer für Schwaben



IHK: Industrie- und Handwerkskammer



## NETWORKERS AT:

MTB Tourismusforum Deutschland



MTB Kongress Österreich



# Contact



+49 831 960 886 10



bike@schneestern.com



Schneestern GmbH & Co KG  
Werner-von-Siemens-Str. 47  
87471 Durach · Germany



[www.schneestern.com/bike](http://www.schneestern.com/bike)

# Imprint

t: +49 (0) 831-960886-10 Schneestern GmbH & Co. KG  
f: +49 (0) 831-960886-40 Werner-von-Siemens-Strasse 47, D-87471 Durach

Schneestern GmbH & Co. KG · Legal form: Limited partnership · Location: Durach · Register court: Kempten HRA 8156 · Personally liable partner: Schneestern Management GmbH · VAT ID No: DE 254363841 · Managing Director: Dirk Scheumann, Kai Siebdrath · Bank: Raiffeisenbank Kempten · IBAN: DE62 7336 9920 0100 2037 85 · BIC: GENODEF1SFO

# Photographers

- Dan Griffith/Red Bull Content Pool
- Fred Lindmooser
- Oliver Schmid-Selig
- Markus Slavik
- Hansueli Spitznagel
- Kaspars Alksnis
- Philipp Ruggli
- Jonathan Junge
- Thomas Dietze
- Markus Frühmann
- Fred Lindmoser
- Ralph Klohs
- Dominik Bosshard
- Hansueli Spitznagel
- Sven Martin
- Filips Smits
- Adrian Greiter
- Manuel Lopez
- Moritz Ablinger
- Johannes Herden
- Irmo Keizer
- Jethro Snyders

# More catalogues

We will be happy to send you a copy by post.



SNOW  
Equipment



SNOW  
Parks

**action sports** engineered